

BOSCH

Invented for life

LBB 1925/10 Plena System Pre-Amplifier



- ▶ **Six-zone system pre-amplifier, with single or dual channel operation**
- ▶ **Two input channels for call stations**
- ▶ **Universal input for microphone/line, with speech optimized tone control**
- ▶ **Three inputs for BGM selection and music optimized tone control**
- ▶ **Front panel zone selection for BGM and call station zone selection for calls**
- ▶ **PC and trigger inputs for automated calls, alarm tones and chimes to selected zones**

The Plena system pre-amplifier is a versatile, high-performance unit with call and mono BGM (background music). It fulfills a wide variety of public address requirements at a surprisingly low cost. It can provide dual channel operation for simultaneous calls and BGM for up to six different zones, using two Plena amplifiers.

Functions

The call channel provides two inputs for the Plena call stations, LBB 1941/00 (all-call) or LBB 1946/00 (six-zone), with loop-through capability, and universal, balanced input. One is a 3-pin XLR connector for microphone or line level (selectable), and the other is a 5-pin DIN-connector with all-call priority contact, which may also be used to start one of the available chime attention signals.

The microphone input has a selectable speech filter for improved intelligibility, a volume control, and bass and treble tone controls with shelving characteristics optimized for speech. The call channel is available on the balanced XLR master output.

The BGM channel provides three inputs on stereo cinch-connectors, converted to mono, with front panel selection, volume control and bass and treble tone controls with shelving characteristics optimized for music. The BGM channel has a direct output on balanced XLR for dual channel operation. It can also feed the master output, with the lowest priority, for single channel operation. Zone selector switches on the front panel control the BGM routing. An overload protected 24 VDC output provides power for driving external relays, often making an external power supply unnecessary.

An emergency/telephone input with signal level detector (VOX) and volume preset has the highest priority to all zones. Two trigger inputs (contact closure) activate alarm or time signals to pre-selected zones. Many different chime tones are available. A PC audio input with RS-232 control provides software controlled zone configuration, or automatic messaging in combination with the LBB 1965/00 Plena Message Manager. There are six levels of priority available for BGM, microphone, call stations, trigger inputs and emergency input. A set of relays directs the amplifier output(s) to different loudspeaker groups (zone switching).

Each zone has a tri-state control on the front panel that can turn it off, switch it to the call channel, or to the BGM channel. The all-call microphone input and emergency activation override the call station selection on the call channel. Each zone has separate priority overrides with preset volume levels. This assures an appropriate message volume, independent of any local volume settings, such as for BGM. Both three-wire and four-wire override schemes are supported. An override also activates a voltage-free contact (call-active) available for external control and monitoring. The master output channel, or one of the input channels, can be monitored through the headphone connector and/or the LED VU-meter.

Controls and indicators

Front

- LED power meter
- Power on LED
- Call active LED
- Three knobs for mic/line volume, treble, and bass levels
- Three knobs for BGM volume, treble, and bass levels
- BGM source selection knob
- Six zone-selections keys
- Six zone status LEDs
- On/off switch

Back

- EMG input volume control
- Mains voltage switch

Interconnections

Front

- Headphone jack

Back

- One (DIN or XLR) Mic/line input
- Two (DIN/DIN) call station inputs
- PC audio (cinch) input
- Priority input
- Master (XLR) output
- BGM (XLR) output
- Emergency signal input
- Two trigger inputs
- RS-232 (DE-9)
- Three (cinch) CD, tape, aux inputs
- Six 100 V speaker outputs
- 24 VDC output
- 24 VDC input
- Three control inputs
- Ground screw
- IEC mains socket

Certifications and Approvals

Region	Certification
Europe	CE Declaration of Conformity

Safety	acc. to EN 60065
Immunity	acc. to EN 55103-2
Emission	acc. to EN 55103-1

Installation/Configuration Notes



LBB 1925/10 rear view

Parts Included

Quantity	Component
1	LBB 1925/10 PLENA System Pre-amplifier
1	Power cord
1	Set of 19" mounting brackets
1	Plena CD
1	Installation and User Instructions

Technical Specifications

Electrical

Mains power supply

Voltage	230/115VAC, ±15%, 50/60 Hz
Current inrush	230/115 VAC, 1.5/3 A
Max power consumption	25 VA

Battery power supply

Voltage	24 VDC, +10% / -15%
Current max	1 A

Performance

Frequency response	50 Hz to 20 kHz (+1 / -3 dB)
Distortion	<0.5%
Bass control	±10 dB @ 100 Hz
Treble control	±10 dB @ 10 kHz
Channel separation	>70 dB @ 1 kHz
Priority mute	>40 dB

Dynamic range	100 dB
---------------	--------

Mic/line input

Connectors	1 x 5-pin DIN, 3-pin XLR, balanced, with phantom power
------------	--

Sensitivity	1 mV (mic), 200 mV (line)
-------------	---------------------------

Mains power supply

Impedance	>1 kohm (mic); >5 kohm (line)
S/N (flat at max volume)	>63 dB (mic); >70 dB (line)
S/N (flat at min volume/muted)	>75 dB
CMRR	>40 dB (50 Hz – 20 kHz)
Headroom	>25 dB
Speech filter	-3 dB @ 315 Hz, high-pass, 6 dB/oct
Phantom power supply	16 V via 1.2 kohm, (mic mode only)
Line input	3 x
Connector	Cinch, stereo converted to mono, unbalanced
Sensitivity	200 mV
Impedance	22 kohm
S/N (flat at max volume)	>70 dB
S/N (flat at min volume/muted)	>75 dB
Headroom	>25 dB
Master output	1 x
Connector	3-pin XLR, balanced
Nominal level	1 V
Impedance	<100 ohm
Tape output	1 x
Connector	Cinch, 2 x mono
Nominal level	350 mV
Impedance	<1 kohm
Headphone output	1 x
Connector	6.3 mm jack stereo, signal mono
Nominal level	3 V
Impedance	<100 ohm
Zone relays	5 A
Contacts voltage	250 V
Contacts current	8 A
Interconnection input / emergency	1 x
Connector	3-pin XLR, balanced
Sensitivity	200 mV (interconnection), 100 mV to 1 V adjustable (emergency)
Impedance	>10 kohm
VOX threshold	45 mV (emergency)
Interconnection output	1 x
Connector	3-pin XLR, balanced
Nominal level	200 mV
Impedance	<100 ohm
Relay contacts	30 V, 1 A
DC supply output voltage	24 V, 250 mA max

Mechanical

Dimensions (H x W x D)	100 x 430 x 270 mm (19" wide, 2U high)
Weight	Approx. 5 kg
Mounting	Standalone, 19" rack
Color	Charcoal

Environmental

Operating temperature	-10 °C to +55 °C (14 °F to +131 °F)
Storage temperature	-40 °C to +70 °C (-40 °F to +158 °F)
Relative humidity	<95%

Ordering Information

LBB 1925/10 Plena System Pre-Amplifier **LBB1925/10**
6-zone, 2-channel distribution system unit
with call and BGM (background music)

Plena System Pre-amplifier and Call Stations



Security Systems

en | Installation and Operating Manual
LBB 1925/10, LBB 1941,
LBB 1946

BOSCH

Important safeguards

- 1 Read instructions - All the safety instructions for use should be read before the system is operated.
- 2 Retain instructions - The safety instructions and instructions for use should be retained for future reference.
- 3 Heed warnings - All warnings on the unit and in the operating instructions should be adhered to.
- 4 Follow instructions - All operating instructions and instructions for use should be followed.
- 5 Cleaning - Unplug system units from the mains outlet before cleaning. Do not use liquid cleaners or aerosol cleaners. Use a damp cloth for cleaning.
- 6 Attachments - Do not use attachments not recommended by the product manufacturer as they may cause hazards.
- 7 Water and Moisture - Do not use this unit near water, for example near a bathtub, washbowl, kitchen sink, or laundry basket, in a wet basement, near a swimming pool, in an unprotected outdoor installation or any area which is classified as a wet location.
- 8 Accessories - Do not place this unit on an unstable stand, tripod, bracket or mount. This unit may fall, causing serious injury to a person and serious damage to the unit. Use only a stand, tripod, bracket or mount recommended by the manufacturer, or sold with the product. Any mounting of the unit should follow the manufacturer's instructions, and should use a mounting accessory recommended by the manufacturer. An appliance and cart combination should be moved with care. Quick stops, excessive force, and uneven surfaces may cause the appliance and cart combination to overturn.
- 9 Ventilation - Openings in the enclosure, if any, are provided for ventilation and to ensure reliable operation of the unit and to protect it from overheating. These openings must not be blocked or covered. The unit should not be placed in a built-in installation unless proper ventilation is provided or the manufacturer's instructions have been adhered to.
- 10 Power sources - Units should be operated only from the type of power source indicated on the marking label. If you are not sure of the type of power supply you plan to use, consult your appliance dealer or local power company. For units intended to operate from battery power, or other sources, refer to the "Installation and User Instructions".
- 11 Grounding or polarisation - This unit may be equipped with a polarised alternating current line plug (a plug having one blade wider than the other). This plug will fit into the power outlet only one way. This is a safety feature. If you are unable to insert the plug fully into the outlet, try reversing the plug. If the plug still fails to fit, contact your electrician to replace your obsolete outlet. Do not defeat the safety purpose of the polarised plug. Alternatively, this unit may be equipped with a 3-wire grounding type plug having a third (grounding) pin. This plug will only fit into a grounding-type power outlet. This is a safety feature. If you are unable to insert the plug into the outlet, contact your electrician to replace your obsolete outlet. Do not defeat the safety purpose of the grounding-type plug.
- 12 Power-Cord Protection - Power supply cords should be routed so that they are not likely to be walked on or pinched by items placed upon or against them, paying particular attention to cords and plugs, convenience receptacles, and the point where they exit from the appliance.
- 13 Overloading - Do not overload outlets and extension cords as this can result in a risk of fire or electrical shock.
- 14 Object and Liquid Entry - Never push objects of any kind into this unit through openings as they may touch dangerous voltage points or short-out parts that could result in a fire or electric shock. Never spill liquid of any kind on the unit.
- 15 Servicing - Do not attempt to service this unit yourself as opening or removing covers may expose to dangerous voltage or other hazards. Refer all servicing to qualified service personnel.
- 16 Damage Requiring Service - Unplug the unit from the outlet and refer servicing to qualified service personnel under the following conditions:
 - When the power-supply cord or plug is damaged.
 - If liquid has been spilled, or objects have fallen into the unit.
 - If the unit has been exposed to rain or water.
 - If the unit does not operate normally by following the instructions for use. Adjust only those controls that are covered by the instructions for use, as an improper adjustment of other controls may result in damage and will often require extensive work by a qualified technician to restore the units to their normal operation.
 - If the unit has been dropped or the unit has been damaged.
 - When the unit exhibits a distinct change in performance; this indicates a need for service.
- 17 Replacement Parts - When replacement parts are required be sure the service technician has used replacement parts specified by the manufacturer or parts which have the same characteristics as the original part. Unauthorised substitutions may result in fire, electric shock or other hazards.
- 18 Safety Check - Upon completion of any service or repairs to the units, ask the service technician to perform safety checks to determine that the unit is in proper operating condition.
- 19 Lightning - For added protection of the units during a lightning storm, or when it is left unattended and unused for long periods of time, unplug it from the wall outlet and disconnect the cable system. This will prevent damage to the unit due to lightning and power-line surges.

About this manual

This manual provides all the information required to install and operate the unit.

Conventions

**Warning**

Follow these instructions to prevent personal injury.

**Caution**

Follow these instructions to prevent damage to the equipment.

**Note**

Read these instructions for tips and other useful information.

Safety precautions

**Warning**

Do not open the unit when it is connected to the mains. The unit contains non-insulated parts, which can cause electric shock.

**Caution**

There are no user-serviceable parts inside the unit. Service must be done by qualified personnel.

Table of contents

Important safeguards.....	3
About this manual	4
Safety precautions.....	4
Table of contents	5
1 About the system pre-amplifier	7
1.1 Controls & Connections (front)	8
1.2 Controls & connections (rear)	8
2 Internal settings (system pre-amplifier)	9
2.1 Setting the zones for trigger 1 and 2	9
2.2 Setting tones	9
2.3 Setting the Speech filter and call station volume	10
2.4 Setting priority	10
2.5 Setting single and dual channel use	11
2.6 Override contact setting	11
3 Installation in rack (system pre-amplifier)	12
4 External settings and connections (system pre-amplifier)	13
4.1 Connect the DC supply (battery)	13
4.2 Connect a microphone	14
4.3 Connect the call stations	15
4.4 Connect an emergency input line	15
4.5 Connect audio sources for background music	16
4.6 Connect to a booster	17
5 Operation (system pre-amplifier)	18
6 About the call stations	19
6.1 Controls & Connections (top)	20
7 Internal settings (call stations)	21
7.1 Chime	21
7.2 Setting sensitivity & speech filter	21
8 Operation (call stations)	22
9 Technical data	23
9.1 System pre-amplifier LBB 1925	23
9.1.1 Electrical	23
9.1.2 Performance	23
9.1.3 Inputs	23
9.1.4 Outputs	24
9.1.5 Relays	24
9.1.6 Environmental conditions	24
9.1.7 General	24
9.2 All-call call station LBB 1941	25
9.2.1 Electrical	25
9.2.2 Performance	25
9.2.3 Environmental conditions	25
9.2.4 General	25
9.3 6-zone call station LBB 1946	26
9.3.1 Electrical	26
9.3.2 Performance	26

9.3.3	Selections	26
9.3.4	Environmental conditions	26
9.3.5	General	26
	Chime tone tables.....	27

1 About the system pre-amplifier

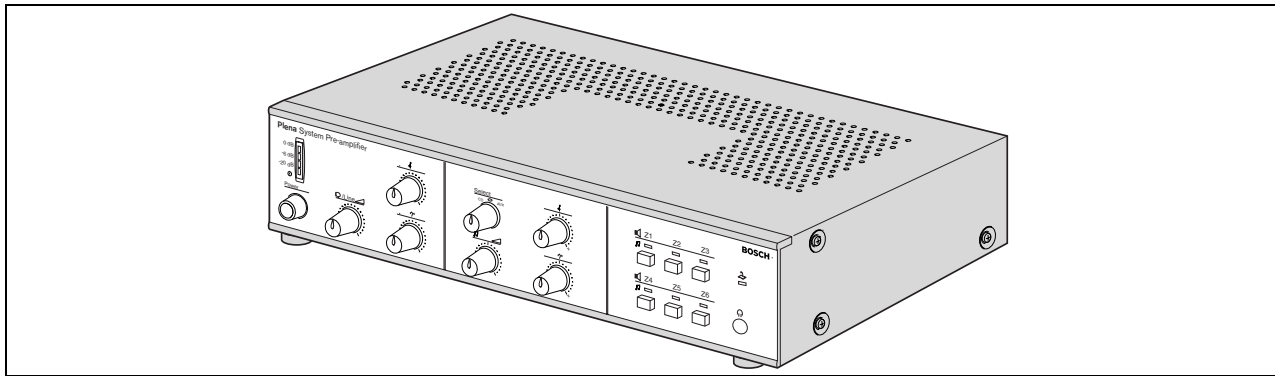

Figure 1.1

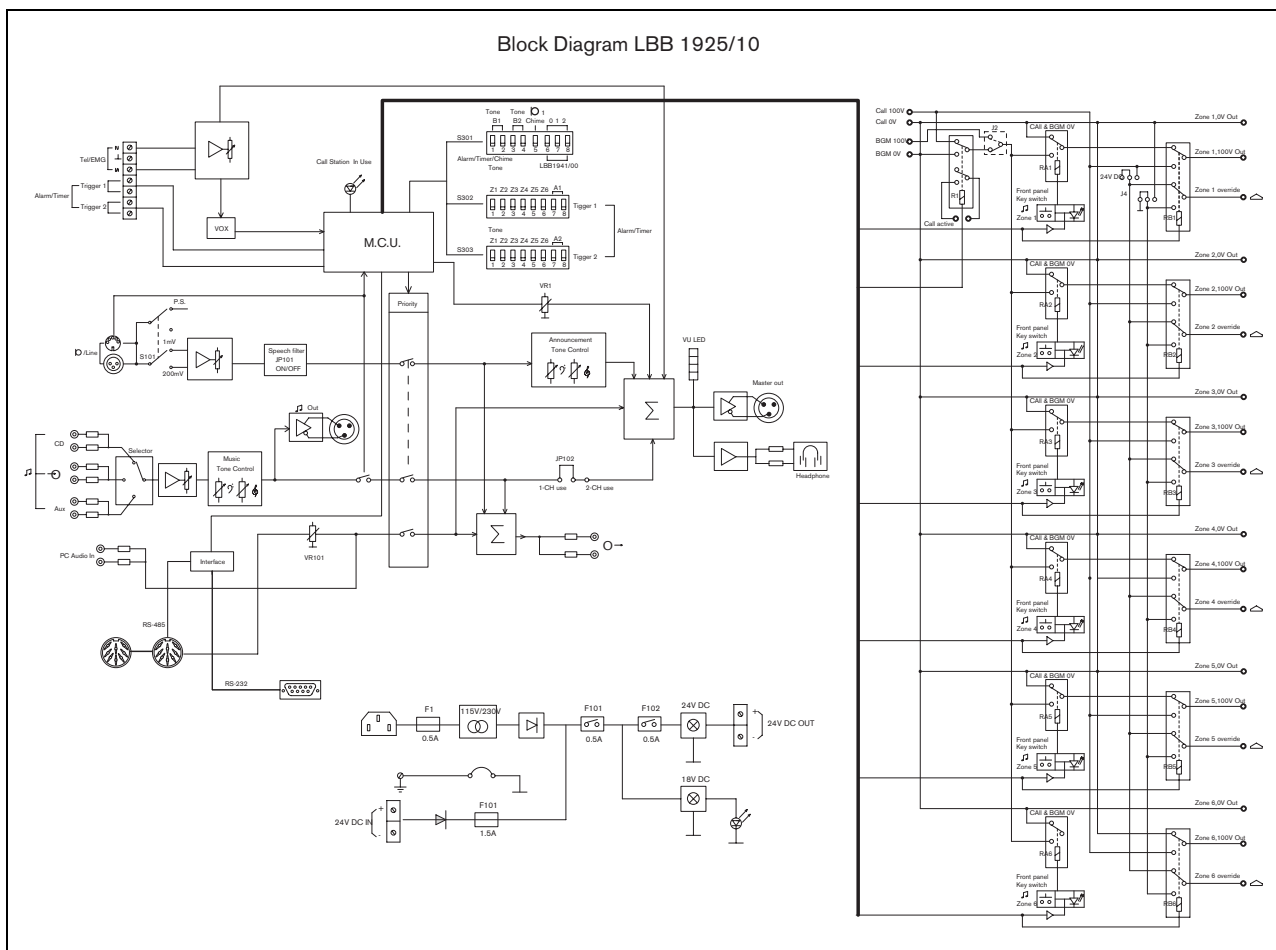

Figure 1.2

The Plena System Pre-amplifier is a mono amplifier, which mixes a call-station signal with a background music signal. You can adjust the volume and tone for both signals. The background music channel has 3 possible inputs (CD, Tape and AUX) and a direct XLR output for 2-channel use. Internal relays control the audio routing to the 6 zones. The zone selection keys at the front determine to which zones the background music is send.

1.1 Controls & Connections (front)

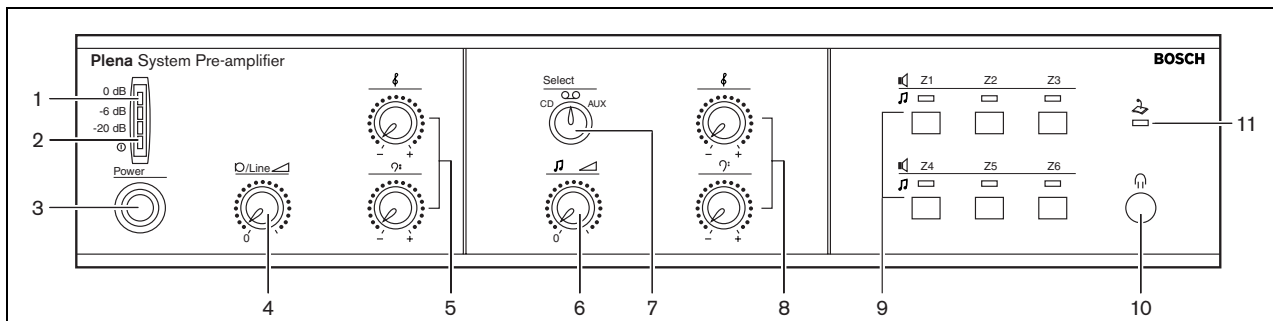

Figure 1.3

- | | |
|------------------------------------|---|
| 1 VU meter (LED bar) | 7 Background music selection switch |
| 2 Power on indication LED (green) | 8 Tone control, background music |
| 3 Power on/off | 9 Zone selection keys, background music |
| 4 Volume control, mic/line | 10 Headphone connection |
| 5 Tone control, mic/line | 11 Indication LED, call station active |
| 6 Volume control, background music | |

1.2 Controls & connections (rear)

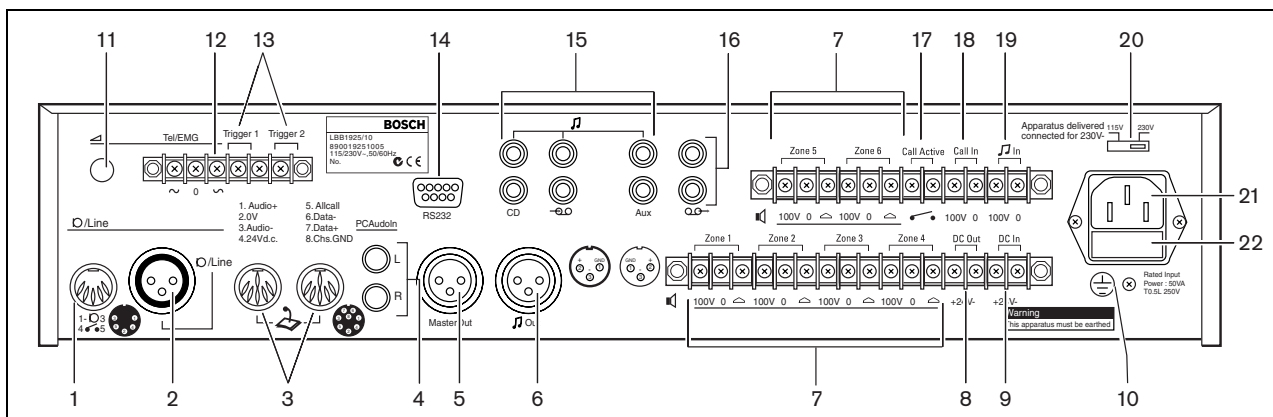

Figure 1.4

- | | |
|---|--|
| 1 Mic/line input (DIN) | 12 Telephone/Emergency signal input |
| 2 Mic/line input (XLR) | 13 Alarm/time signal, trigger inputs |
| 3 Call station input (8-pin DIN) | 14 Control input for PC (RS232; 9-pin) |
| 4 Audio input from PC (Cinch) | 15 CD/ Tape/Auxiliary input (Cinch) |
| 5 Master output (XLR) | 16 Tape output (Cinch) |
| 6 Background music output (XLR) | 17 Call active control output (terminal) |
| 7 100V LSP output (zone 1 to 6) | 18 Call input from booster (terminal) |
| 8 24V DC output for relays (terminal) | 19 Music input from booster (terminal) |
| 9 24V DC input (terminal) | 20 Mains voltage switch (115/230V) |
| 10 Earth connection screw | 21 Mains socket |
| 11 Volume control (Tel/Emergency input) | 22 Mains fuse |

2 Internal settings (system pre-amplifier)

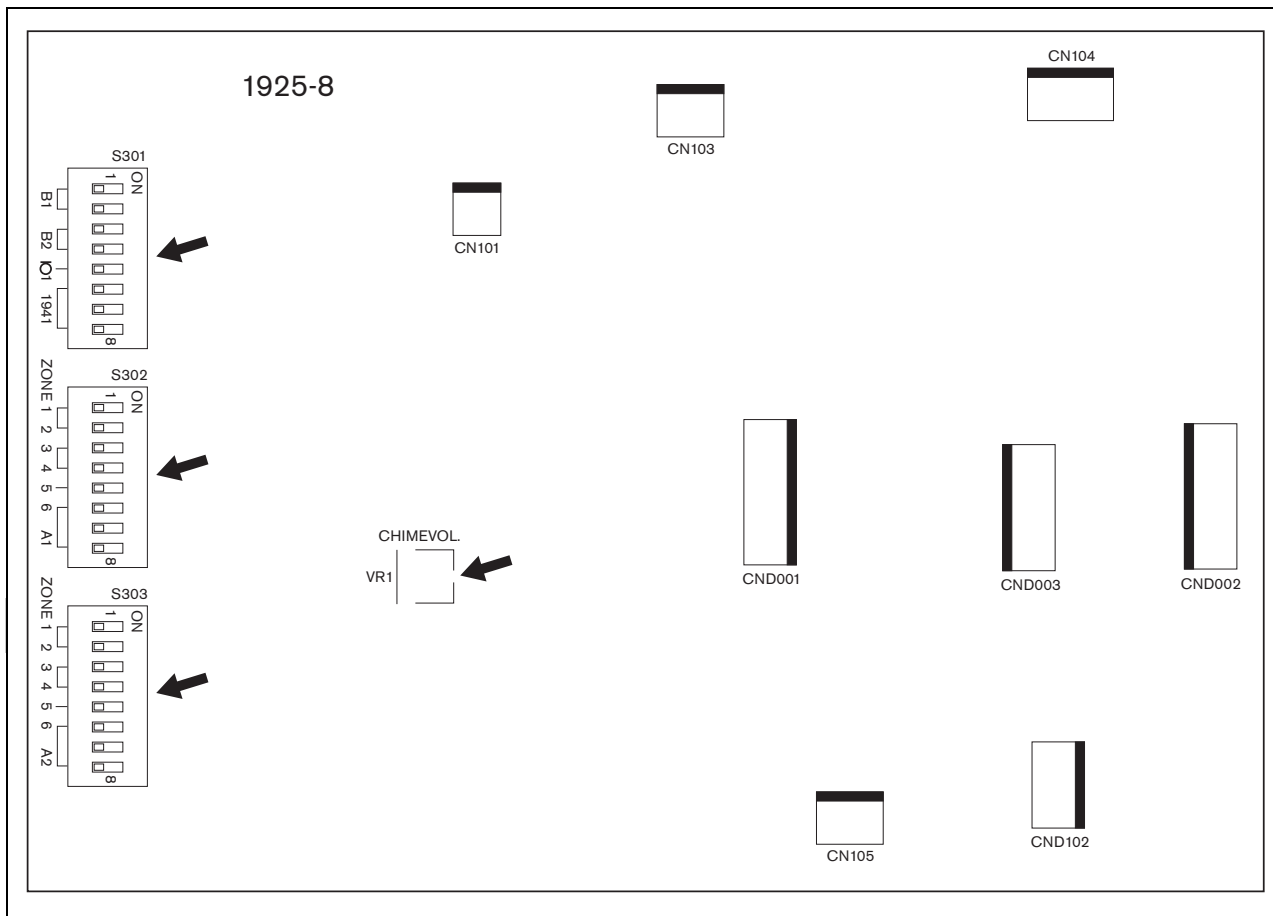

Figure 2.1

2.1 Setting the zones for trigger 1 and 2

Trigger inputs 1 and 2 on the rear panel may start alarm or time signals upon closing its contact. The zones for trigger 1 can be set with S302 (bit 1 to 6), for trigger 2 with S303 (bit 1 to 6). The selected zones receive a time or alarm tone when the trigger is activated. Time tones are edge triggered and last the duration of the chime. Alarm tones are level triggered and last until released.

2.2 Setting tones

The time or alarm tone for trigger 1 can be set with S301 (bit 1 and 2) and S302 (bit 7 and 8), for trigger 2 with S301 (bit 3 and 4) and S303 (bit 7 and 8). If you use a LBB 1941 call station, the chime tone must be set with S301 (bit 6 to 8). You can find the chime tone tables at the end of the manual. With S301 (bit 5) the 2-tone chime on the DIN priority contact for mic/line can be enabled or disabled. The 2-tone chime is 554 Hz (1s), 440 Hz (1s). You can set the chime volume with VR1.

2.3 Setting the Speech filter and call station volume

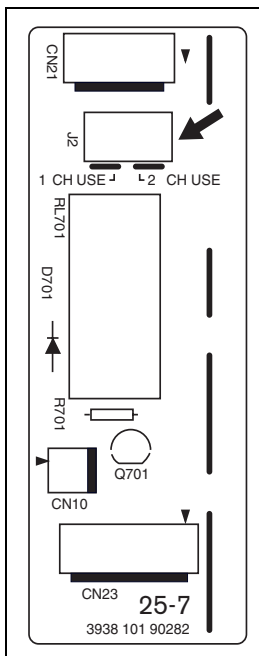

Figure 2.2

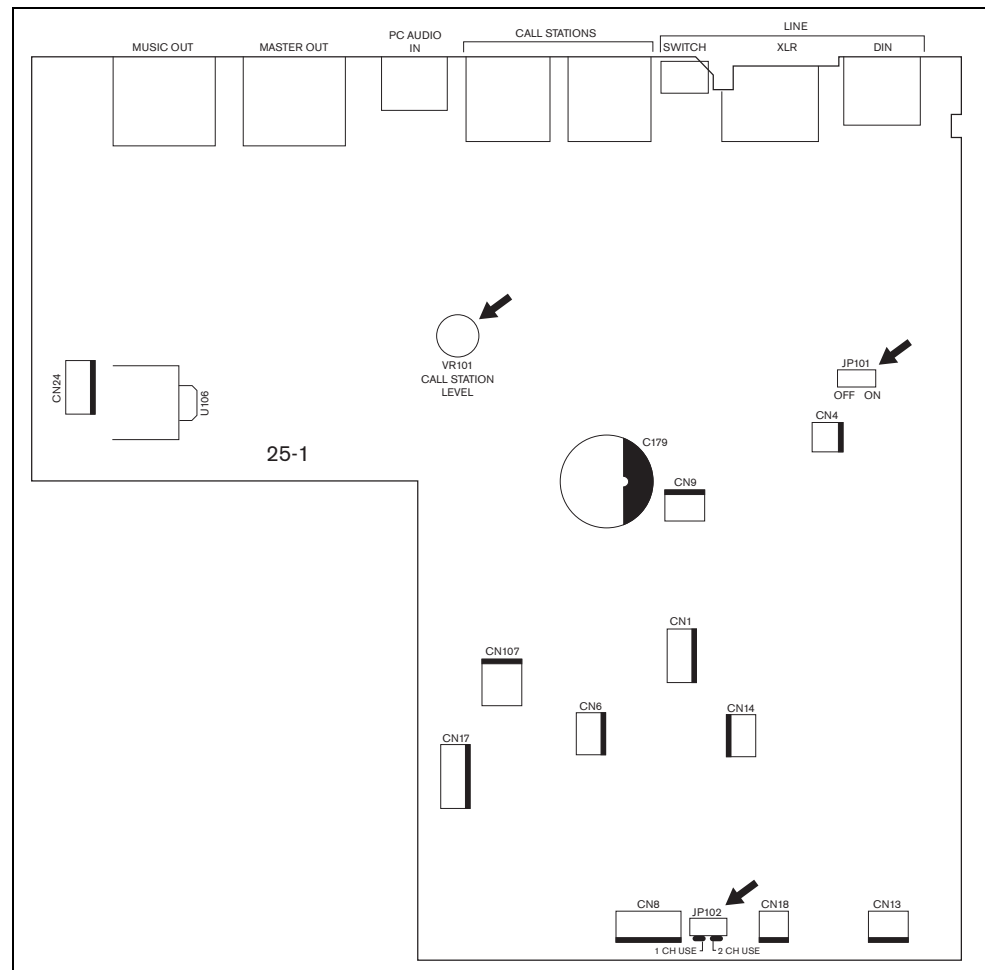

Figure 2.3

The Speech filter for the mic/line input can be switched on/off with jumper JP101 (default ON). You can set the call station volume with VR101.

2.4 Setting priority

The priority cannot be set manually. The default priority order is:

- 1 Emergency/Telephone input
- 2 Trigger 1 or 2 (first comes, first served)
- 3 All-call call station LBB 1941
- 4 6-zone call station LBB 1946 (DIP switch setting of LBB 1946)
- 5 6-zone call station LBB 1946 (DIP switch setting of LBB 1946)
- 6 Background music and mic/line input

2.5 Setting single and dual channel use

The system pre-amplifier can be used with one booster amplifier for both music and calls ('1 channel use'). Any call will interrupt background music in all zones. It is also possible to use separate booster amplifiers, for music and calls ('2 channel use'). Now a call will not interrupt music in zones, not addressed by the call. Jumper JP102 selects whether background music is going to the Master output (1 channel use) or not (2 channel use). Jumper J2 must be set to either 1 channel use or 2 channel use to select the amplifier terminals for the zones.

2.6 Override contact setting

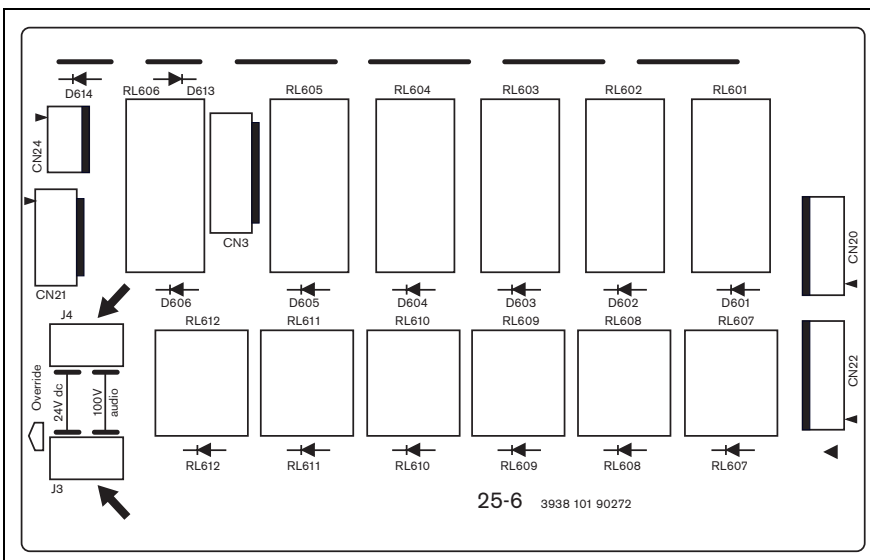

Figure 2.4

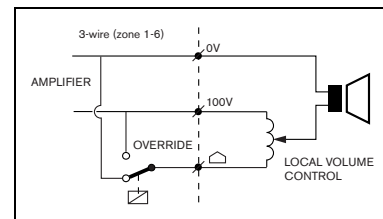

Figure 2.5

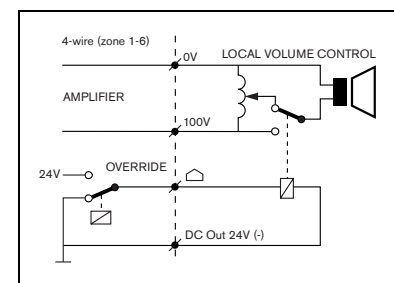



Figure 2.6

Jumpers J3 and J4 select whether the override output for each zone (indicated by ) is switching between the 0V and 100V loudspeaker signal, or between ground and 24Vdc. This override output is available per zone and may be used to override local volume controls, to make sure that calls are coming through. For 3-wire volume override, the jumpers should be in 100V audio position. For 4-wire override the jumpers should be in 24Vdc position. The drawings show the principle of 3- and 4-wire volume override. The override outputs are activated whenever a call is made, when the emergency input is activated, or an alarm or time signal is triggered. At the same time also the Call Active relay is activated, providing a potential free contact.

3 Installation in rack (system pre-amplifier)

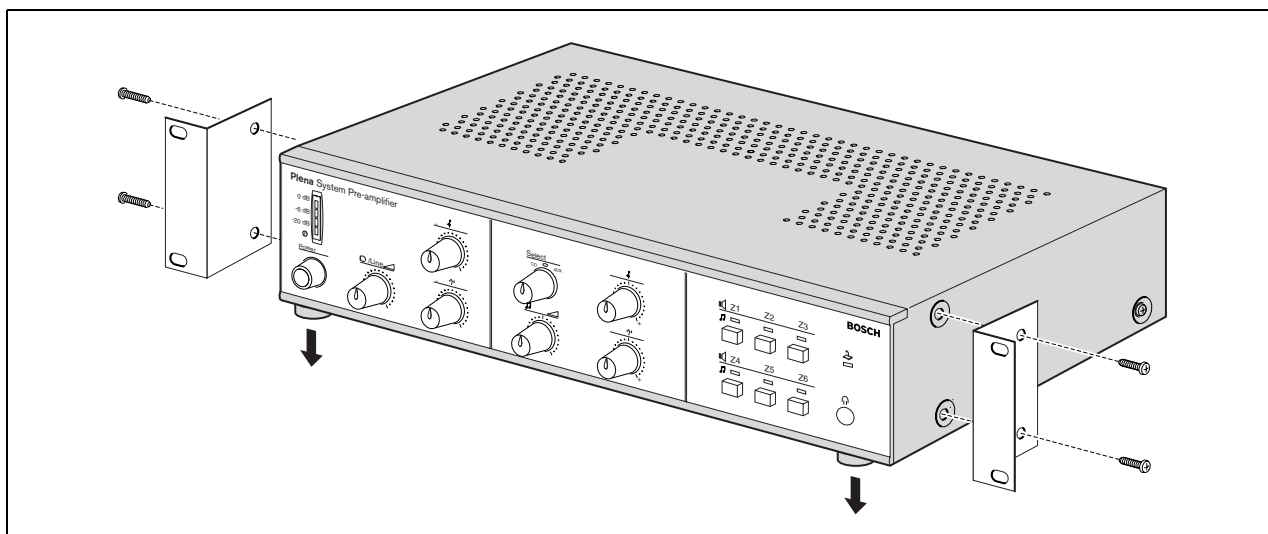

Figure 3.1

The system pre-amplifier is delivered for tabletop use, but you can mount it in a 19" rack.

If you mount the pre-amplifier in a rack, you must:

- use the mounting brackets delivered with the unit.
- remove the 4 feet from the bottom of the unit. (Without the feet the unit is 2U high.)

4 External settings and connections (system pre-amplifier)

4.1 Connect the DC supply (battery)

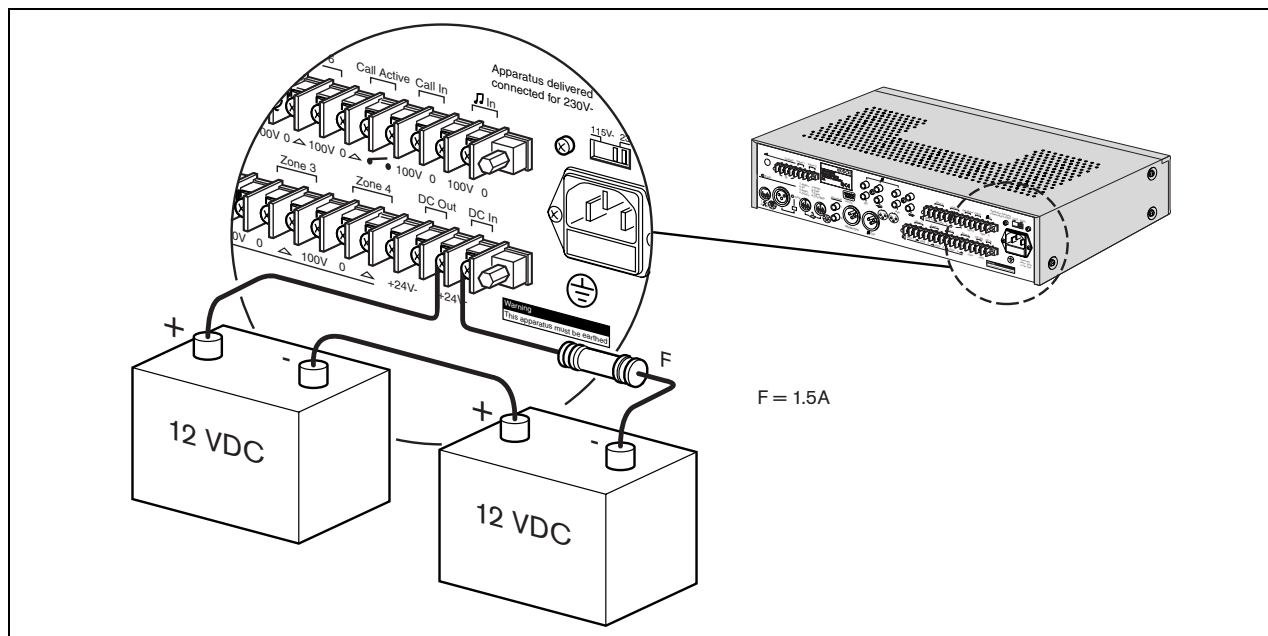

Figure 4.1

The system pre-amplifier has a 24 Vdc input (terminal screw), which you can use to connect a back up power supply, e.g. batteries. You can earth the unit to increase the electrical stability of the system.



Caution

The connection cable must have an in-line fuse. Use the type of fuse as mentioned in the illustration.

4.2 Connect a microphone

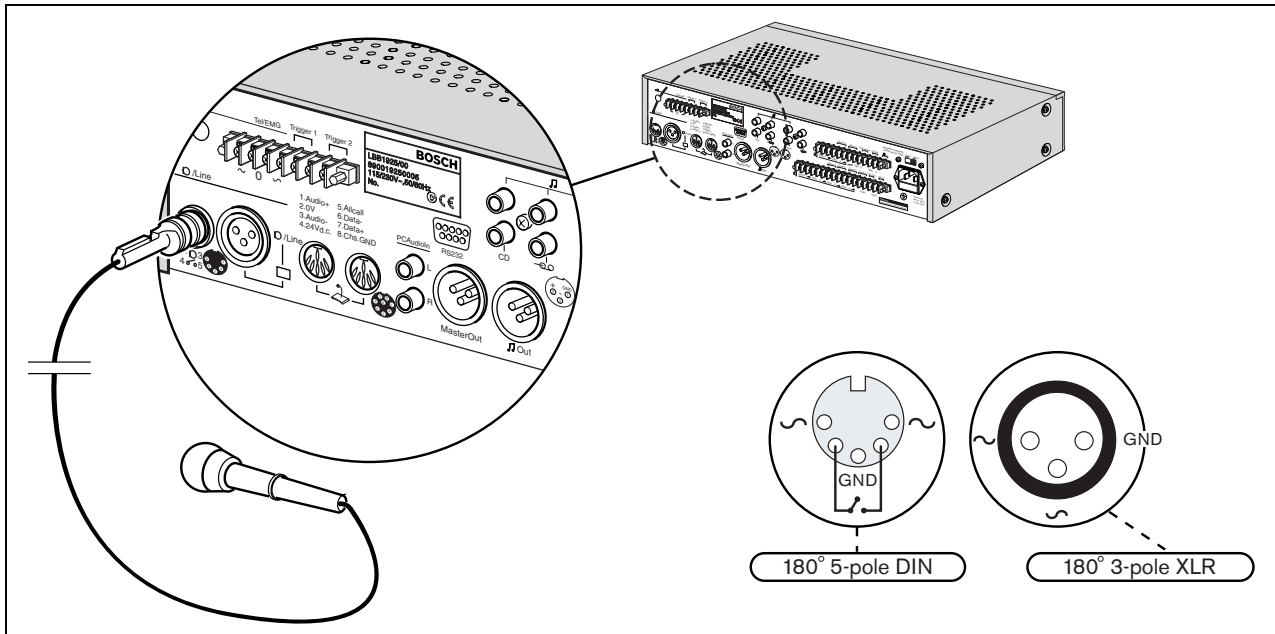

Figure 4.2

The input channel has 2 possible balanced inputs, use one of these inputs to connect a microphone or a line-level source. If you use an input make sure that the 'mic/line' switch is in the correct position.



Note

If you want to use the priority feature, you must use a microphone or line-level source with a priority contact on pin 4 and 5 of the 5-pole DIN plug.

4.3 Connect the call stations

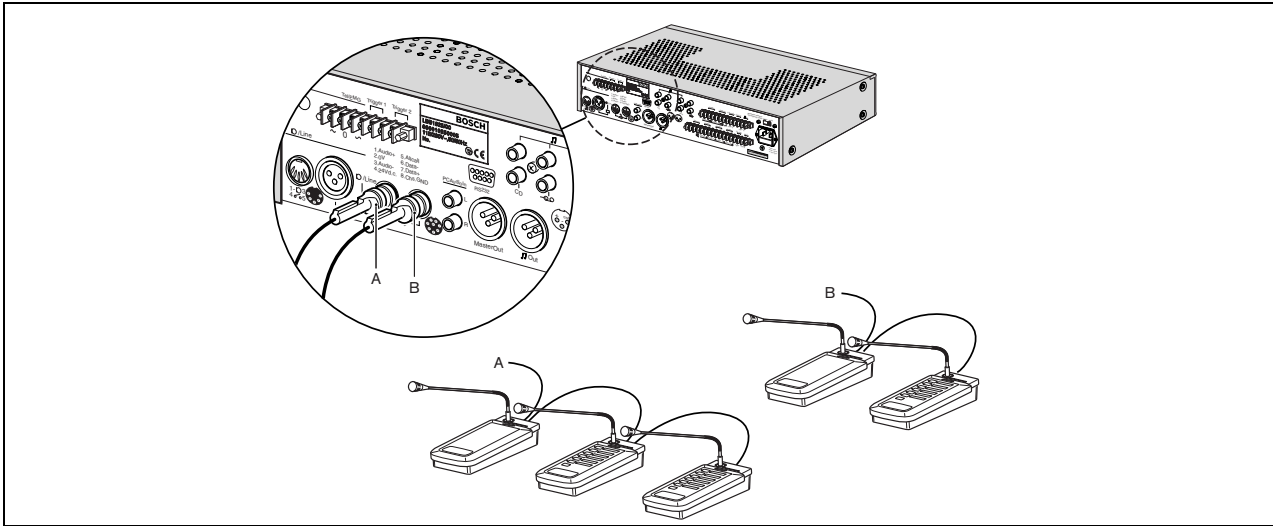

Figure 4.3

You can connect 2 Plena Call Stations directly to the system pre-amplifier. To connect up to the maximum of 8 call stations you must use a loop through connection. The loop through can contain both types of call stations.

4.4 Connect an emergency input line

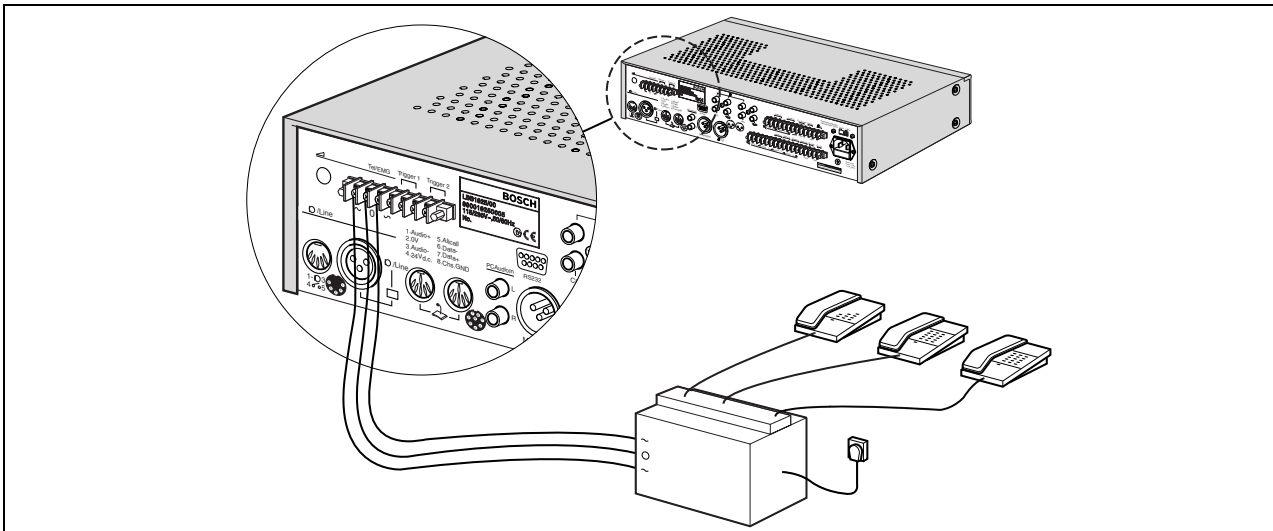

Figure 4.4

You can use this input for emergency announcements and/or signals. This channel has the highest priority and is always transmitted to all zones. The emergency line has its own volume control on the rear, this volume is not affected by the master volume. If a priority microphone, call station, emergency input or trigger input is activated, the Call Active relay is closed and the override contacts of the selected loudspeaker zones are activated.

4.5 Connect audio sources for background music

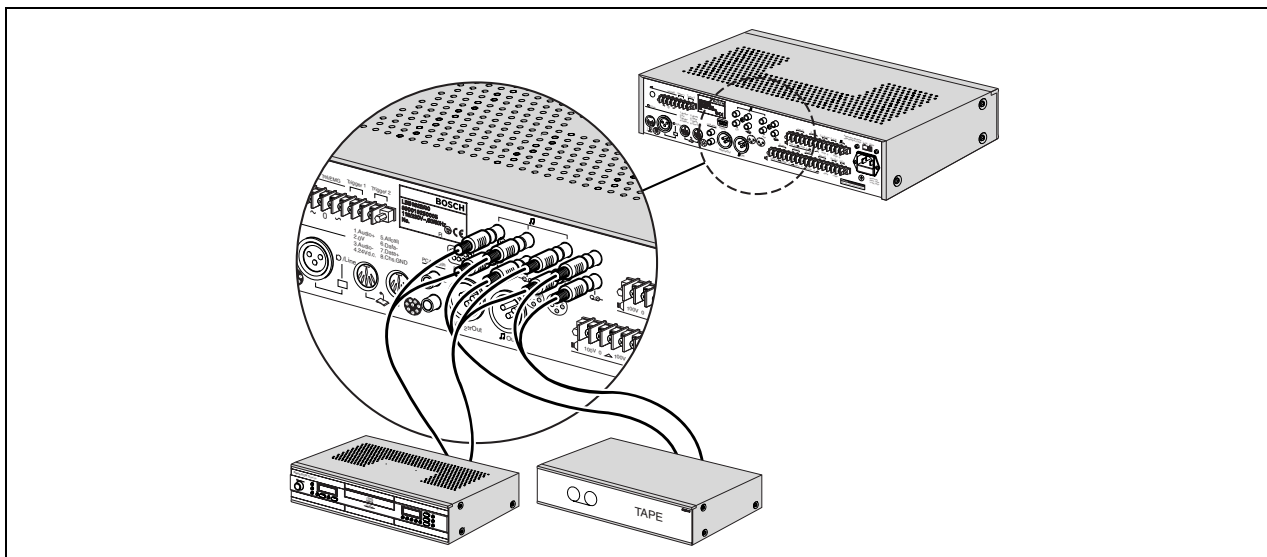

Figure 4.5

The system pre-amplifier has 3 connections for background music (CD, Tape & Auxiliary). You can connect 3 units but only one of the inputs is used depending on the selection switch at the front. It is also possible to use the output of a PC soundcard to supply music or time signals to the system pre-amplifier. To do so connect the soundcard output to the 'PC Audio In' input.

4.6 Connect to a booster

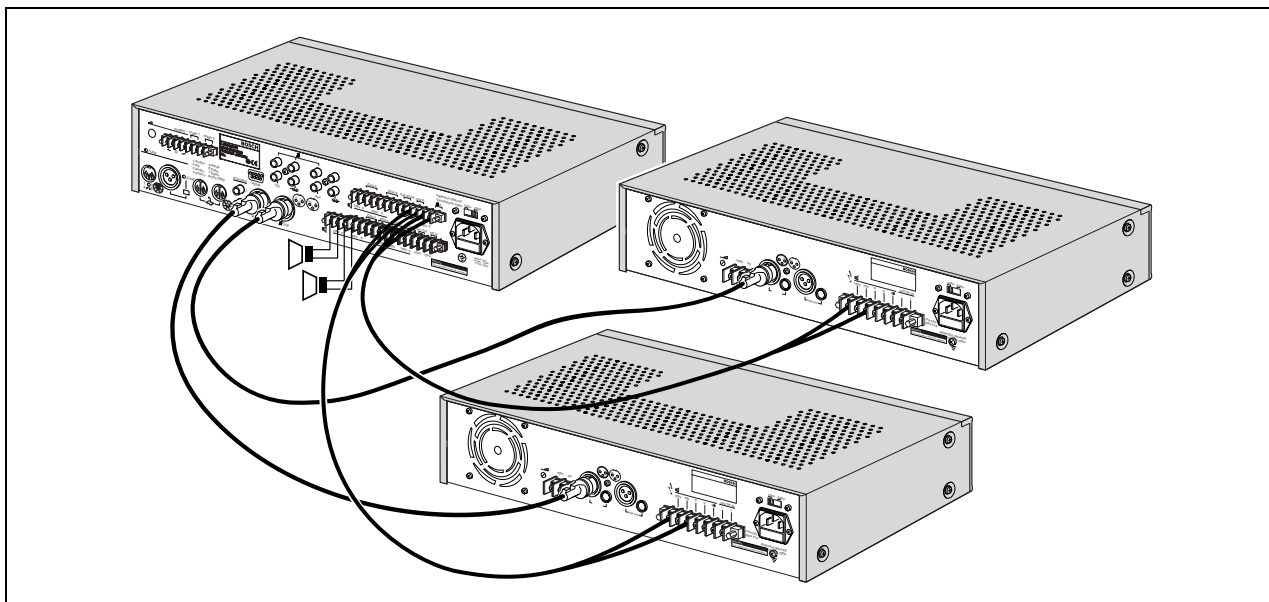

Figure 4.6

The system pre-amplifier has a master and a music output that can be connected to 1 or 2 boosters for single or dual channel operation. For single channel operation connect the Master output to the booster. The signal from the booster must be returned to the 'Call in' (terminal) of the system pre-amplifier. For dual channel operation you must also connect the Music output to a second booster. The signal from this booster must be returned to the 'Music in' (terminal) of the system pre-amplifier.

5 Operation (system pre-amplifier)

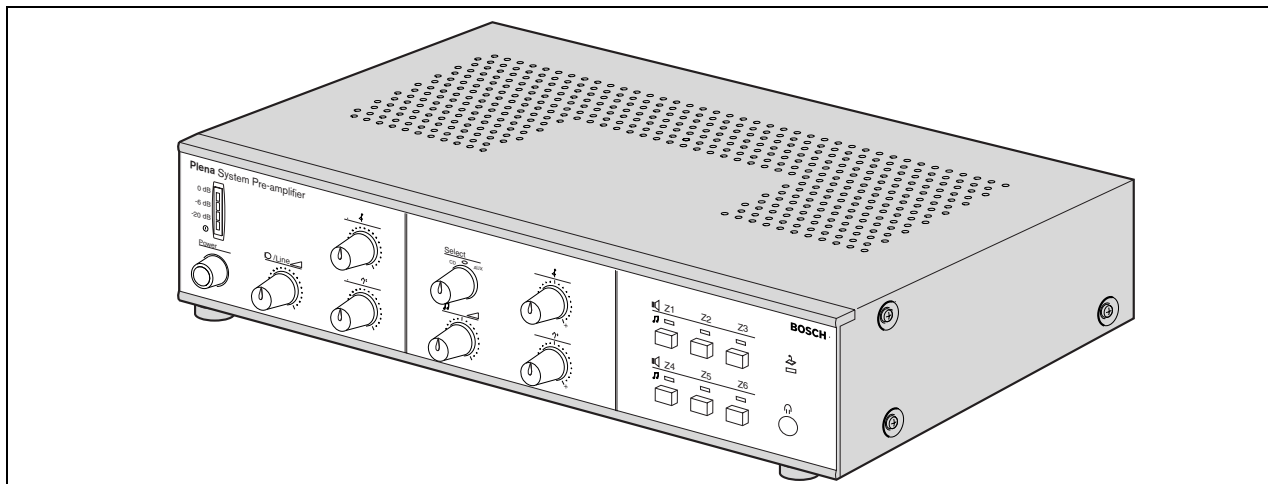

Figure 5.1

You can adjust the volume and tone for the mic/line input with the knobs on the left panel. The knobs for background music selection, volume and tone are on the centre panel. To select the zones to which the background music must be sent press the keys on the right hand panel. When a zone is active the indication LED is on.

6 About the call stations

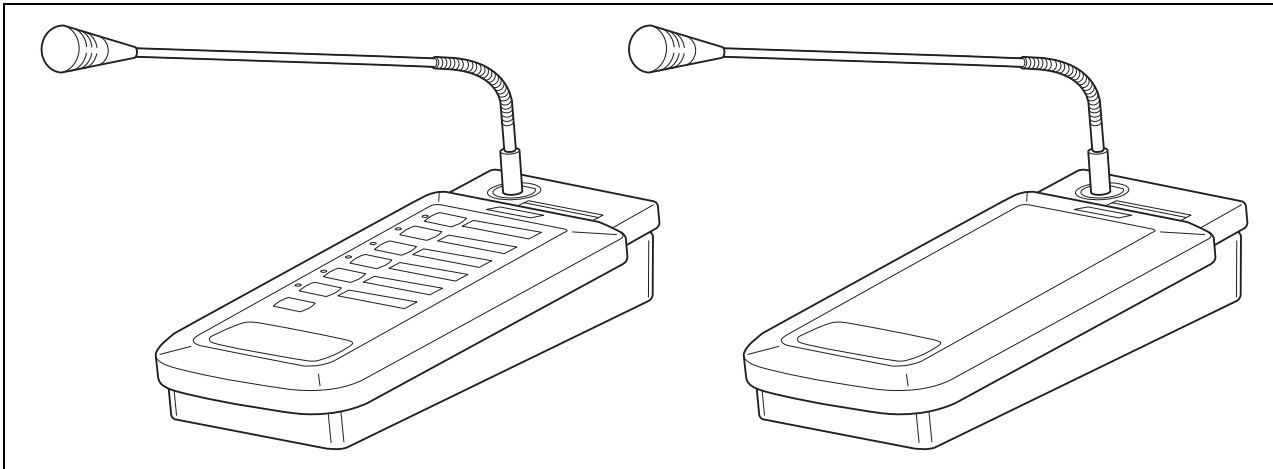

Figure 6.1

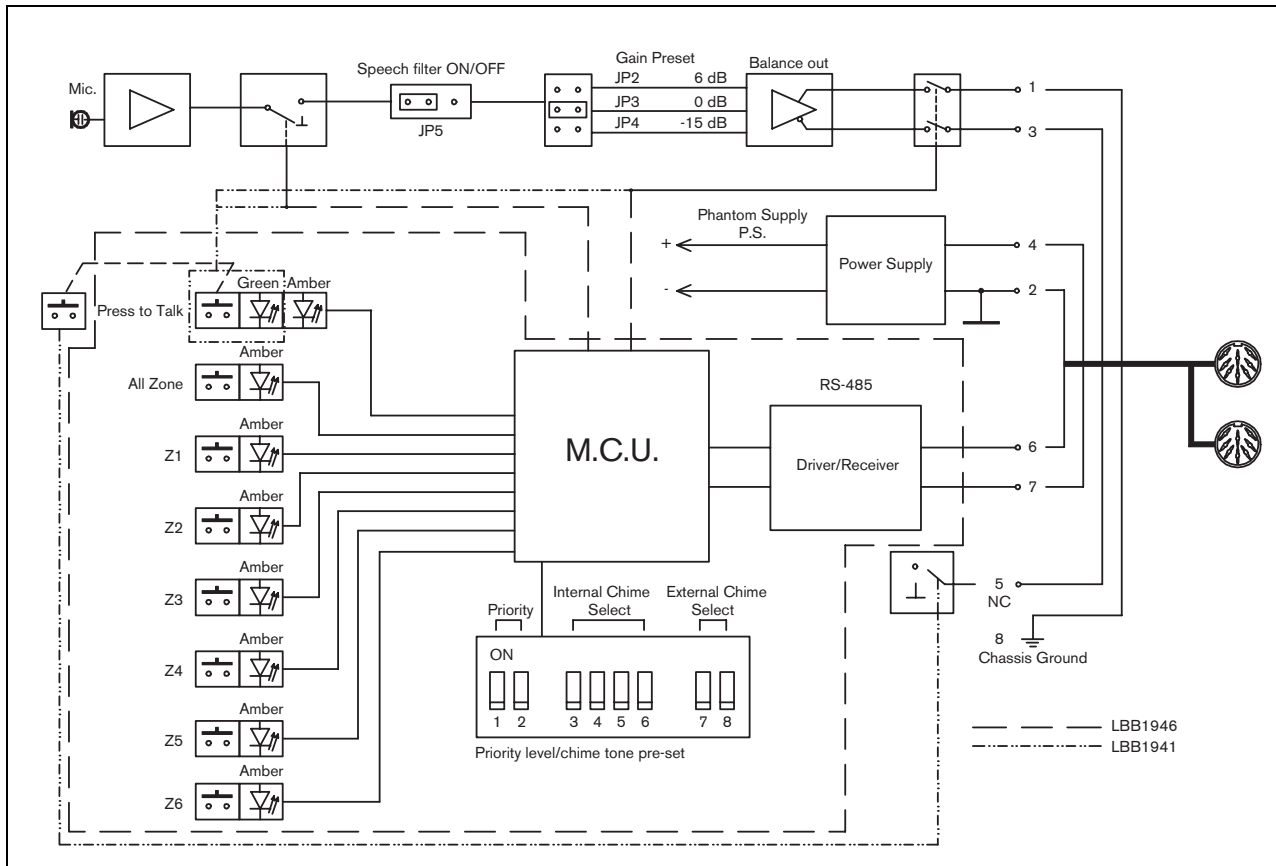

Figure 6.2

The Plena Call Stations must be used in combination with the system pre-amplifier LBB 1925. Both call stations have a loopthrough connection to add an additional call station. The 6-zone call station (LBB 1946) has the possibility to send a message to one zone, a group of zones or all zones. The all-call call station (LBB 1941) can only send a message to all zones.

6.1 Controls & Connections (top)

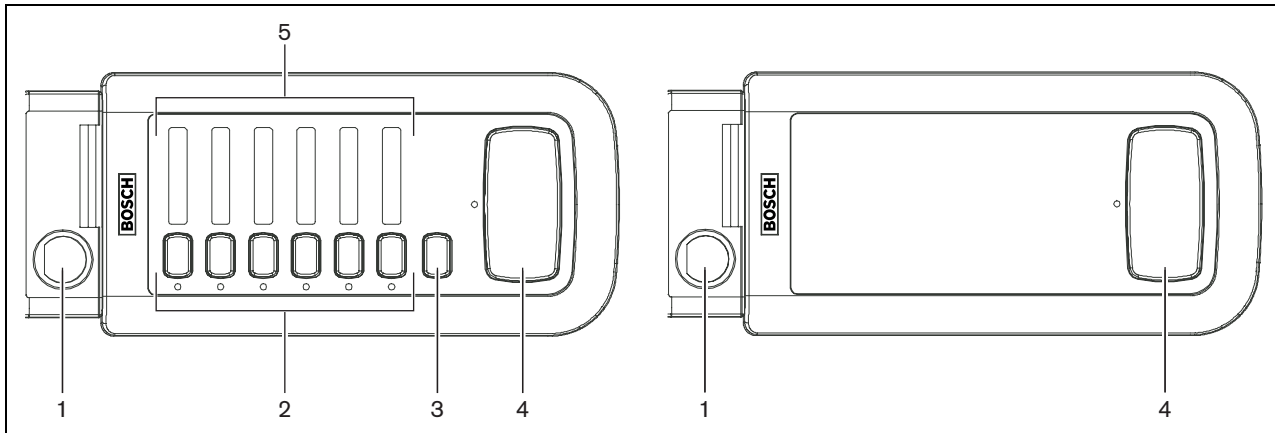

Figure 6.3

- 1 Microphone
- 2 Zone selection keys with indication LED
- 3 All zone selection key with indication LED
- 4 Press to talk key with indication LED
- 5 Labels for zone indication.



Note

An editable label template (MS Word) can be downloaded from www.boschsecuritysystems.com / www.philipscsi.com.

The call stations LBB 1941 and LBB 1946 can be connected in a loop-through arrangement to the LBB 1925. Each input of the LBB 1925 can have up to 4 call stations. The call station cable may be extended up to 500 m from the LBB 1925, using shielded CAT-5 quality cable (four twisted pairs with one overall shield) and 8-pin DIN connectors. One twisted pair for power supply connection (DIN pin 4: 24Vdc, pin 2: ground), one twisted pair for data communication (DIN pin 6: data -, pin 7: data +), one twisted pair for audio (DIN pin 1 and pin 3) and one twisted pair for all-call select (DIN pin 5) and connection to chassis ground (DIN pin 8).

7 Internal settings (call stations)

7.1 Chime

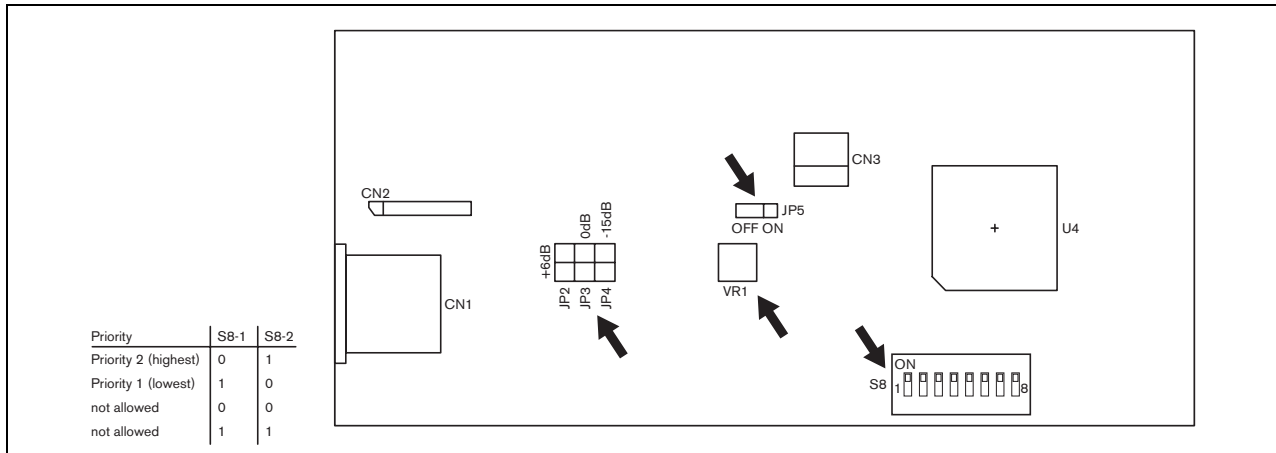

Figure 7.1

The chime for the all-call call station (LBB 1941) is set inside the LBB 1925 system pre-amplifier. The chime for the 6-zone call station (LBB 1946) is set within the call station with DIP switch S8 (bit 3 to 8). The chime volume can be set with VR1. You can find the chime tone tables at the end of the document. The priority for a call station (LBB 1946) can be set with the switch S8 (bit 1 and 2) as shown in figure 7.1.

7.2 Setting sensitivity & speech filter

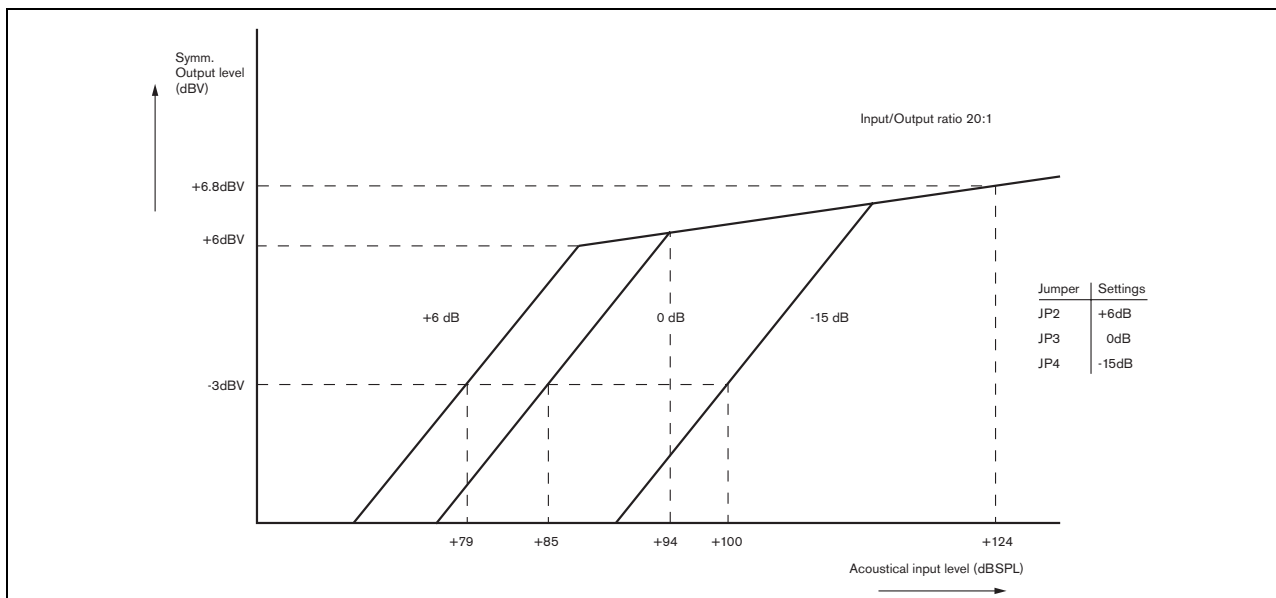

Figure 7.2

The sensitivity of the call station microphone can be set with the jumpers JP2, JP3 and JP4. Which jumper activates which sensitivity can be found in the table. The speech filter can be enabled or disabled with jumper JP5.

8 Operation (call stations)

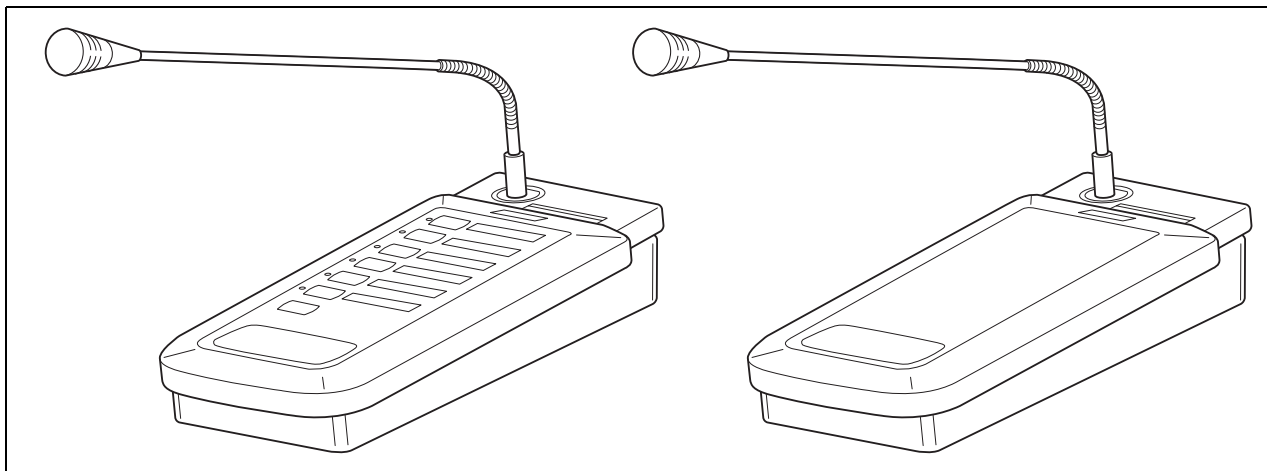

Figure 8.1

The call station LBB 1941 can only send a call to all zones. With the call station LBB 1946 you can select to which zones your call is sent. To do so press the zone keys or the all-zone key. When a zone is selected the indication LED is on. To send a call press the PTT key and wait until the indication LED is green, then talk in the microphone. The indication LED can give the following indications.

Indication LED of PTT button		Call station type
Yellow	The system is occupied.	Only LBB 1946
Yellow flashing	The PTT key is pressed, but no zones were selected.	Only LBB 1946
Green	The microphone is on.	Both
Green flashing	The chime tone is active.	Only LBB 1946

9 Technical data

9.1 System pre-amplifier LBB 1925

9.1.1 Electrical

Mains voltage	230 V/115 Vac, (15%, 50/60 Hz)
Max mains power consumption	50 VA
Battery voltage	24 Vdc, +20%/-10%
Max battery current	1 A

9.1.2 Performance

Frequency response	50 Hz - 20 kHz (+1/-3 dB)
Distortion	<0.5%
Call channel	
Bass control	-6/+6 dB at 160 Hz
Treble control	0/+12 dB at 5 kHz
BGM channel	
Bass control	0/+20 dB at 100 Hz
Treble control	0/+18 dB at 15 kHz
Channel separation at 1kHz	>65 dB
Priority mute	>50 dB

9.1.3 Inputs

Call station inputs (8-pin DIN, balanced, for LBB1941/00 and/or LBB1946/00)

Sensitivity	1 V
Data	RS485, 1200, N, 8, 1, 0

Mic/Line input (3-pin XLR/5-pin DIN, balanced)

Sensitivity	1 mV (microphone), 200 mV (line)
Impedance	>1 kOhm (microphone), >5 kOhm (line)
S/N (flat at max volume)	>63 dB (microphone), >70 dB (line)
S/N (flat at min volume/muted)	>75 dB
CMRR	>40 dB (50 Hz - 20 kHz)
Headroom	>25 dB
Speech filter	-3 dB at 315 Hz, high-pass, 6 dB/oct
Phantom power supply	16 V via 1.2 kOhm, in microphone mode only

BGM input (Cinch, unbalanced, stereo converted to mono)

Sensitivity	500 mV (CD), 200 mV (aux, tape)
Impedance	22 kOhm
S/N (flat at max volume)	>70 dB
S/N (flat at min volume/muted)	>75 dB
Headroom	>25 dB

PC input (Cinch, unbalanced, stereo converted to mono)

Sensitivity	1 V
Impedance	22 kOhm
S/N	>70 dB

Emergency/telephone input (Screw, balanced)

Sensitivity	100 mV to 1V adjustable
Impedance	>10 kOhm
VOX threshold	50 mV
S/N	>65 dB

9.1.4 Outputs**Master output (3-pin XLR, balanced)**

Nominal level	1V
Impedance	<100 Ohm

BGM output (3-pin XLR, balanced)

Nominal level	1 V
Impedance	<100 Ohm

Tape output (Cinch, 2x mono)

Nominal level	350 mV
Impedance	3.3 kOhm

Headphone output (6.3-mm jack stereo, signal mono)

Nominal level	3 V
Impedance	<100 Ohm

Control

RS232 (9-pin D-sub)	
Baud rate	19K2

Trigger inputs (Screw)

Activation	contact closure
------------	-----------------

9.1.5 Relays

Priority relay contacts	100 V, 2 A
Zone output relay contacts	100 V, 2 A
DC supply output voltage	24 V, 250 mA max

9.1.6 Environmental conditions

Operating temperature range	-10 to +55°C
Storage temperature range	-40 to +70°C
Relative humidity	<95%

9.1.7 General

EMC emission	acc. to EN 55103-1
EMC immunity	acc. to EN 55103-2
Dimensions	100 x 430 x 270 mm (19" wide, 2U high)
Weight	approx. 5 kg
19" mounting brackets included	

9.2 All-call call station LBB 1941

9.2.1 Electrical

Power supply

Voltage range	18 to 24 V (24 V supplied by LBB1925/10)
Current consumption	<30 mA

9.2.2 Performance

Nominal sensitivity	85dB SPL (gain preset 0dB)
Nominal output level	700mV
Maximum input sound level	110 dB SPL
Gain preset	+6/0/-15 dB
Limiter threshold	2 V
Compression ratio limiter	1:20
Distortion	<0.6% (maximum input)
Equivalent input noise level	25 dBA SPL
Frequency response	100 Hz to 16 kHz
Speech filter	-3 dB at 315 Hz, high-pass, 6 dB/oct
Output impedance	200 Ohm

9.2.3 Environmental conditions

Operating temperature range	-10 to +55°C
Storage temperature range	-40 to +70°C
Relative humidity	<95%

9.2.4 General

EMC emission	acc. to EN 55103-1
EMC immunity	acc. to EN 55103-2
Dimensions	40 x 100 x 235 mm (base) 390 mm stem length (with microphone)
Weight	approx. 1 kg
Cable length	5 m (may be extended up to 500 m using CAT-5 style shielded cable)

9.3 6-zone call station LBB 1946

9.3.1 Electrical

Power supply	
Voltage range	18 to 24 V (24 V supplied by LBB1925/10)
Current consumption	< 30 mA

9.3.2 Performance

Nominal sensitivity	85 dB SPL (gain preset 0 dB)
Nominal output level	700 mV
Maximum input sound level	110 dB SPL
Gain preset	+6/0/-15 dB
Limiter threshold	2 V
Compression ratio limiter	1:20
Distortion	< 0.6% (maximum input)
Equivalent input noise level	25 dBA SPL
Frequency response	100 Hz to 16 kHz
Speech filter	-3 dB at 315 Hz, high-pass, 6 dB/oct
Output impedance	200 Ohm

9.3.3 Selections

Chimes	18 different combinations
Priorities	2 different priorities

9.3.4 Environmental conditions

Operating temperature range	-10 to +55°C
Storage temperature range	-40 to +70°C
Relative humidity	< 95%

9.3.5 General

EMC emission	acc. to EN 55103-1
EMC immunity	acc. to EN 55103-2
Dimensions	40 x 100 x 235 mm (base) 390 mm stem length (with microphone)
Weight	approx. 1 kg
Cable length	5 m (may be extended up to 500 m using CAT-5 style shielded cable)

Chime tone tables

Trigger 1	B1		A1	
	S301-2	S301-1	S302-8	S302-7
Trigger 2	B2		A2	
	S301-4	S301-3	S303-8	S303-7
Slow whoop 500 to 1200Hz sweep in 1 s and pause for 1 second	0	0	0	0
Din alarm 1200 to 500Hz sweep in (1s)	0	0	0	1
Evacuation 554Hz (100ms), 440Hz (400ms)	0	0	1	0
Immediate danger 600Hz (200ms), pause (200ms)	0	0	1	1
Fire alarm 440Hz (12s on, 12s off)	0	1	0	0
600Hz continuous	0	1	0	1
Two-tone alarm 440Hz (1s), 554Hz (1s)	0	1	1	0
Pulse alarm 1000Hz (300ms), pause (200ms)	0	1	1	1
1.2kHz (1s)	1	0	0	0
554Hz (2s)	1	0	0	1
440Hz (4s)	1	0	1	0
554Hz (2s)	1	0	1	1
554Hz (1s), 440Hz (1s)	1	1	0	0
392Hz (1s), 523Hz (1s), 659Hz (2s)	1	1	0	1
554Hz (1s), 440Hz (1s), 493Hz (1s), 330Hz (2s)	1	1	1	0
659Hz (1s), 523Hz (1s), 392Hz(1s), 330Hz (2s)	1	1	1	1

Tone LBB 1941	S301-8	S301-7	S302-6
No Chime	0	0	0
554Hz (1s)	0	0	1
554Hz (1s), 440Hz (1s)	0	1	0
392Hz (1s), 523Hz (1s), 659Hz (2s)	0	1	1
554Hz (1s), 440Hz (1s), 493Hz (1s), 330Hz (2s)	1	0	0
196Hz (1s), 262Hz (1s), 330Hz (1s), 392Hz (2s)	1	0	1
392Hz (1s), 523Hz (1s), 659Hz (2s) and release tone in reverse order	1	1	0
196Hz (1s), 262Hz (1s), 330Hz (1s), 392Hz (2s) and release with tones 659Hz (1s), 523Hz (1s), 392Hz (1s), 330Hz (2s)	1	1	1

LBB1946 DIP-SWITCH setting for chime and priority	Chime selection						Priority selection	
	BIT8	BIT7	BIT6	BIT5	BIT4	BIT3	BIT2	BIT1
554Hz (1s), 440Hz (1s)	0	1	x	x	x	x	-	-
554Hz (1s), 440Hz (1s), 493Hz (1s), 330Hz (2s)	1	0	x	x	x	x	-	-
196Hz (1s), 262Hz (1s), 330Hz (1s), 392Hz (2s)	1	1	x	x	x	x	-	-
No Chime	0	0	0	0	0	0		
440Hz (1s)	0	0	0	0	0	1	x	x
554Hz (1s)	0	0	0	0	1	0	x	x
392Hz (1s), 523Hz (1s), 659Hz (2s)	0	0	0	0	1	1	x	x
392Hz (1s), 523Hz (1s), 659Hz (2s) and release with tones in reverse order	0	0	0	1	0	0	x	x
554Hz (1s), 440Hz (1s) and released with 330Hz (1s), 440Hz (1s)	0	0	0	1	0	1	x	x
554Hz (1s), 440Hz (1s), 493Hz (1s), 330Hz (2s) and release with tone in reverse order	0	0	0	1	1	0	x	x
554Hz (1s), and release with 440Hz (1s)	0	0	0	1	1	1	x	x
196Hz (1s), 262Hz (1s), 330Hz (1s), 392Hz (1s) and release with 659Hz (1s), 523Hz (1s), 392Hz (1s), 330Hz (2s)	0	0	1	0	0	0	x	x
440Hz (0.5s)	0	0	1	0	0	1	x	x
554Hz (0.5s), 440Hz (0.5s)	0	0	1	0	1	0	x	x
392Hz (0.5s), 523Hz (0.5s), 659Hz (0.5s)	0	0	1	0	1	1	x	x
392Hz (0.5s), 523Hz (0.5s), 659Hz (0.5s) and release with tone in reverse order	0	0	1	1	0	0	x	x
554Hz (0.5s), 440Hz (0.5s), 493Hz (0.5s), 330Hz (1s)	0	0	1	1	0	1	x	x
554Hz (0.5s), 440Hz (0.5s), 493Hz (0.5s), 330Hz (1s) and release with tone in reverse order	0	0	1	1	1	0	x	x
196Hz (0.5s), 262Hz (0.5s), 330Hz (0.5s), 392Hz (0.5s) and release with reverse 659Hz (0.5s), 523Hz (0.5s) 392Hz (0.5s), 330Hz (1s)	0	0	1	1	1	1	x	x
Priority level 2	x	x	x	x	x	x	1	0
Priority level 1	x	x	x	x	x	x	0	1
No allowed	x	x	x	x	x	x	1	1