

New Matrix Series

Bosch Commercial Public Address Solutions Amplifiers, Microphones and Speakers



BOSCH

Invented for life



WES 2013

UPDATED AUGUST 2013

→ **Bosch PA Speakers**



BOSCH
Invented for life



BOSCH PA LOUDSPEAKER RANGE

Without compromising on quality, Bosch loudspeakers provide an overall lower cost of ownership. All of its acoustical products meet, or exceed, international standards. They are robust, require minimal power and are easy to install and maintain. And while proud of its technical proficiency, Bosch strives always to match the highest audio quality with great looking design.

- High quality
- Excellent sound reproduction
- Easy to install and maintain



BOSCH PANEL LOUDSPEAKERS

The Bosch panel loudspeakers and matching mounting boxes are ideal for built-in sound installations in shops, department stores, schools, offices, hotels and restaurants. They are manufactured and finished to the same exacting standards as all Bosch public address systems and components, guaranteeing high quality, and compatibility throughout the range.

OPTIONAL VOLUME CONTROL

Watt	9W	
Taps	0.75/1.5/6/6W	
Size	284x165x65mm	
SPL	88dB	
dBi	96dB	
Details	Without Volume	With Volume
Code	LBC3011/41	LBC3011/51

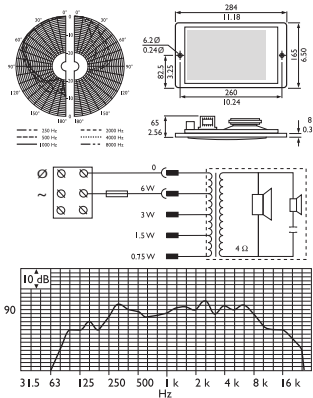

BOSCH PA CEILING SPEAKERS BCS-CS RANGE

The BCS-CS Series of Ceiling Loudspeakers are part of the latest 'EasyFit' range. BCS-CS Loudspeakers are lightweight, quick and easy to install, and are finished in unobtrusive white with an attractive metal grille. Their wide frequency range and dispersion ensure good quality music reproduction and excellent speech intelligibility.

- Wide bandwidth for music reproduction
- Wide dispersion for speech intelligibility
- Simple output-level selection
- Easily flush-mounted in ceilings or bulkheads
- Dependable rota-clamp fixing system
- Blends in with virtually all interiors



Details	4" Easy-Fit	5" Easy-Fit	6.5" Easy-Fit	8" Easy-Fit	8" Easy-Fit
Watt	8W max	8W max	15W max	22W max	45W max
Taps	0.33, 0.5, 1, 2.5, 5W	0.33, 0.5, 1, 2.5, 5W	1.25, 2.5, 10W	1.25, 2.5, 5, 10, 15W	3.75, 7.5, 15, 30W
Size	110x170mmØ	90x200mmØ	115x220mmØ	103x273mmØ	115x273mmØ
SPL	89dB	90dB	91dB	93dB	93dB
dBi	94dB	97dB max	101dB max	105dB max	108dB max
Code	BCS-CS4BW	BCS-CS5BW	BCS-CS6E	BCS-CS8BW	BCS-CS830E

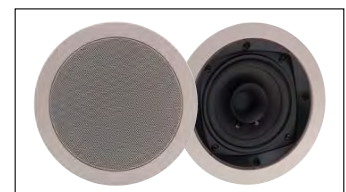



BOSCH PA CEILING 6" LBC

DUAL CONE METAL GRILLE

Voice alarm loudspeakers are specifically designed for use in buildings where performance of systems for verbal evacuation announcements is governed by regulations. The LBC 3086/41 is designed for use in voice alarm systems.

- Suitable for speech and music reproduction
- Flush-mounting in ceiling cavity
- Easy to install
- Simple power setting
- Optional certified fire dome

Details	6"
Watt	6Wrms 9Wmax
Taps	0.75/1.5/3/6W
Size	90x216mmØ
SPL	90dB
dBi	98dB
Code	LBC3090/31



FIREHOME

Steel. Red.

Size	87x147mmØ
Code	LBC3080/01

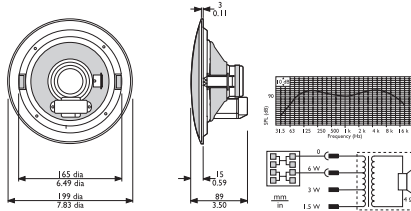

BOSCH PA CEILING 6" LBC SAFETY

DUAL CONE METAL GRILLE FIRE SAFETY RATED

Voice alarm loudspeakers are specifically designed for use in buildings where performance of systems for verbal evacuation announcements is governed by regulations. Designed for use in voice alarm systems.

- Suitable for speech and music reproduction
- Flush-mounting in ceiling cavity
- Easy to install
- Simple power setting
- Optional certified fire dome

Safety ratings
 EN 60065
 BS 5839-8
 EN 60849
 EN 60529-IP32
 *EN 54-24
 (*With fire dome)

Details	6" Dual Cone
Watt	9W
Taps	0.75/1.5/3/6W
Size	90x216mmØ
SPL	90dB
dBi	98dB
Code	LBC3086/41

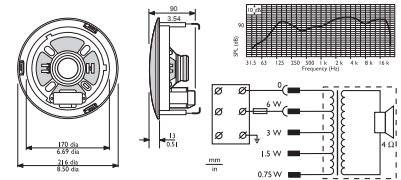
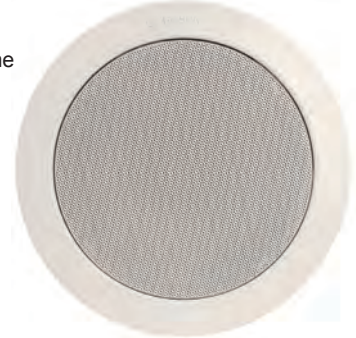

FIREHOME

Steel. Red.

Size	100x157mmØ
Code	LBC3081/02

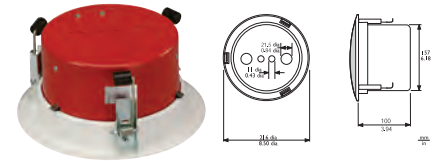

BOSCH PA CEILING 6" LBC POLY

POLY COVER FIRE SAFE

The LBC 3090/01 is an economic flush-mounting ceiling loudspeaker for general purpose applications. It is a full range loudspeaker for speech and music reproduction in shops, department stores, schools, offices, sports halls, hotels and restaurants.

- Suitable for speech and music
- Increased sensitivity
- Flush-mounting in ceiling cavity
- Easy to install
- Protective dust cover

Safety
 EN 60065

Details	6" polly Grill
Watt	6Wrms 9Wpeak
Taps	1.5/3/6W
Size	88x210mmØ
SPL	91dB
dBi	103dB
Code	LBC3090/01

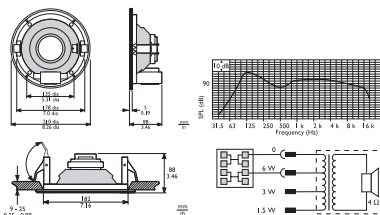

SURFACE MOUNT

Adaptor. Off-white.

Size	93x210mmØ
Code	LBC3091/01

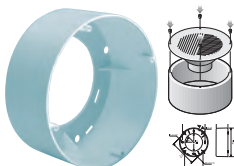

FIREHOME

Steel. Red.

Size	87x147mmØ
Code	LBC3080/01



BOSCH PA CEILING 8"

Flush-mounting ceiling loudspeaker for applications where extra power is required, such as rooms with high ceilings. It delivers a high sound pressure level and has a wide frequency range to ensure excellent speech intelligibility and good quality music reproduction. It is used in applications like shops, department stores, schools, offices, sports halls, hotels and restaurants.

- Excellent speech and music reproduction
- High sound pressure level
- Ideal for high-ceiling applications
- Flush mounted in ceilings
- Clamp mounting

Details	8" Dual Cone
Watt	36W
Taps	6/12/24W
Size	89x265mmØ
SPL	92dB
dBi	106dB
Code	LBC3099/41



FIREHOME

Steel. Red.

Size	100x182mmØ
Code	LBC3082/00

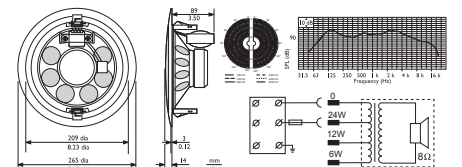

BOSCH PA HORN SPEAKER 6 1/2"

Horn Loudspeaker is specifically designed for excellent sound reproduction in marine applications and other industrial environments. It is rugged, water and dust protected, and resistant to the corrosive effects of seawater and most industrial atmospheres. Suitable for both stationary and mobile systems, its strength and good acoustic performance also makes it ideal for general commercial applications.

- Suitable for marine and industrial applications
- Glass reinforced polyester with strong, fire retardant qualities
- Corrosion and chemical resistant
- Reduced maintenance costs
- IP 67

Details	6.5" White IP67
Watt	15W (22Wmax)
Taps	0.8, 2, 4, 5, 7.5, 15w
Size	245x163mmØ
SPL	102dB
dBi	114dB
Code	LBC3428/00



BOSCH PA HORN 7 1/2"

The LBC 3470/00 is a 15 W high-efficiency circular horn loudspeaker, provide excellent speech reproduction and sound distribution for a wide scope of indoor and outdoor applications. It is ideal for sports grounds, parks, exhibition areas, factories and swimming pools. The horn is made from ABS and finished in light gray.

- High-efficiency driver
- Excellent speech reproduction
- Versatile mounting bracket
- Water-and dust protected to IP 65
- Complies with international installation and safety regulations

Details	ABS Horn
Watt	22.5W
Taps	3.75/7.5/15W
Size	225x190mmØ
SPL	103dB
dBi	115dB
Code	LBC3470/00



BOSCH PA HORN SPEAKER SQUARE

POPULAR RECTANGULAR SHAPE

Bosch high-efficiency horn loudspeakers provide excellent speech reproduction and sound distribution for a wide scope of outdoor applications. They are ideal for sports grounds, parks, exhibitions, factories, pools, etc.

- High efficiency driver
- Up to 45 W (max. power)
- Wide opening angle
- Excellent speech reproduction
- Simple power setting

Details	Rectangular Horn
Watt	15W
Taps	2.5/5/10W
Size	267x171x276mm
SPL	108dB
dBi	121dB
Code	LBC3491/12

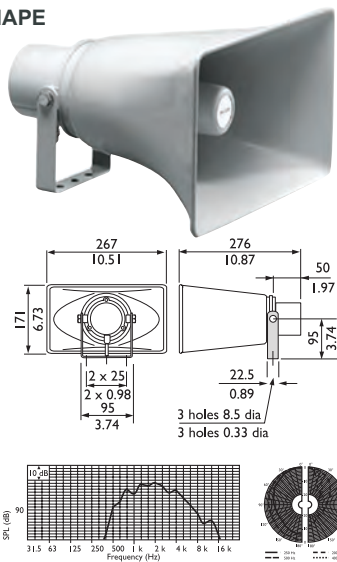

BOSCH PA HORN SPEAKER 8" & 9 1/2"

High-efficiency horn loudspeakers provide excellent speech reproduction and sound distribution for a wide scope of paging and emergency evacuation applications.

- 10W & 20W Models available
- IP66 Rated outdoor use
- Emergency Evacuation System ready
- Wide dispersion for speech intelligibility
- Screwdriver adjustable power tapping
- Loop in / Loop out wiring

Details	8" White IP66	9.5" White IP66
Size	230x200mmØ	292x246mmØ
Watt	10W	20W
Taps	1.25, 2.5, 5, 10W	5, 7.5, 10, 15, 20W
SPL	108dB	110dB
dBi	119dB max	124dB max
Code	BCS-HS10E	BCS-HS20E



BOSCH PA HORN SPEAKER HI-FI

2-WAY MUSIC QUALITY

The Bosch LH1-UC30E Music Horn Loudspeaker features a two-way system, resulting in an extended frequency range and high sensitivity which makes it ideal for high quality speech and music reproduction.

- Excellent speech and music reproduction
- Two-way system
- Wide opening angle
- Attractive ABS housing
- Provisions for internal mounting of the optional line / loudspeaker supervision board

Details	Two Way HiFi
Watt	45W
Taps	3.75/7.5/15/30W
Size	370x255x291mm
SPL	100dB
dBi	115dB
Code	LH1-UC30E

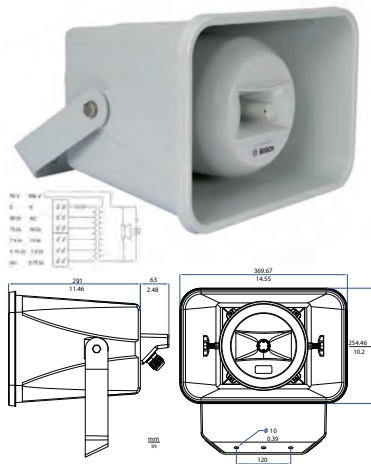

BOSCH PA HORN SPEAKER 14"

LARGE AREA BROADCAST

Bosch high-efficiency horn loudspeakers provide excellent speech reproduction and sound distribution for a wide scope of outdoor applications. They are ideal for sports grounds, parks, exhibitions, factories, swimming pools, etc.

- High efficiency driver
- Up to 45 W (max. power)
- Wide opening angle
- Excellent speech reproduction
- Simple power setting

Details	14" ABS Horn
Watt	30W
Taps	5/10/20W
Size	332x354mmØ
SPL	110dB
dBi	125dB
Code	LBC3493/12





BOSCH 20" HORN LOUDSPEAKER 50W

Highly accurate speech reproduction and powerful sound distribution is ideal for outdoor use such as sporting events, exhibits, swimming pools, etc. The durable aluminum construction is protected against impact by a PVC rim around the edges. Designed for use in voice alarm systems and is compliant with emergency standards.

- High efficiency driver
- Excellent speech reproduction
- Provision for inside mounting of the optional line/loudspeaker supervision board
- Water-and dust protected to IP65
- BS 5839-8 and EN 60849 compliant

Details	20" Horn 50W Aluminium
Watt	52.5W
Taps	9/18/36W
Size	500x490mmØ
SPL	111dB
dBi	117dB
Code	LBC3483/00

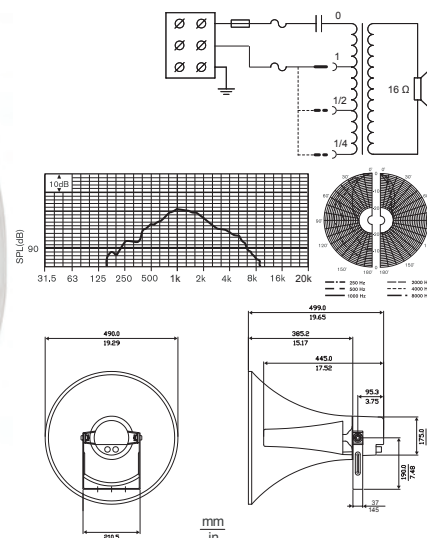

BOSCH 20" HORN LOUDSPEAKER 75W

Bosch high-efficiency horn loudspeakers provide excellent speech reproduction and sound distribution for a wide scope of outdoor applications. They are ideal for sports grounds, parks, exhibitions, factories and swimming pools. This 50 W horn loudspeaker, measuring 490 mm (19.6 in) in diameter is made from aluminum. The edges of the horns are covered with a PVC profile for protection against impact damage. They are light grey (RAL 7035), and are water and dust protected.

- High efficiency driver
- Excellent speech reproduction
- Provision for inside mounting of the optional line/loudspeaker supervision board
- Water and dust protected to IP 65
- BS 5839-8 and EN 60849 compliant

Details	20" Horn 75W Aluminium
Watt	75W
Taps	12.5/25/50W
Size	500x490mmØ
SPL	110dB
dBi	127dB
Code	LBC3484/00

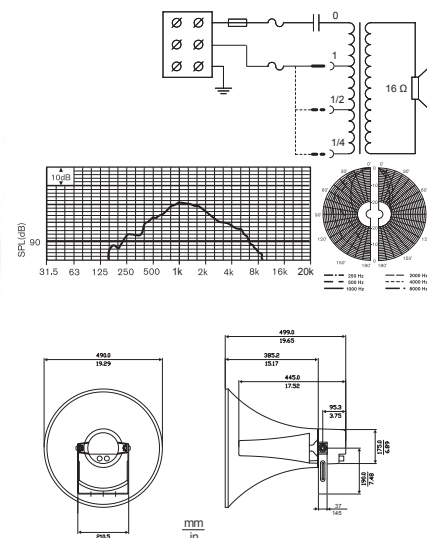

BOSCH HORN DRIVER - LBN SERIES

REQUIRES HORN 1 3/8"

The Bosch professional horn loudspeaker system comprises a range of three high-efficiency driver units that can be installed into one of the compatible circular and rectangular horns (supplied separately without drivers). A standard 1 3/8" screw thread is used for mounting the drivers into horns. All models are treated against corrosion.

- High efficiency
- 30W or 50W versions
- 1 3/8" screw thread
- Simple power setting
- Complies with international installation and safety regulations

Details	Driver Only	Driver Only
Watt	30W	50W
Taps	10/15/20/30W	30/35/40/50W
Size	134x104mmØ	162x118mmØ
SPL	114dB	114dB
dBi	129dB	131dB
Code	LBN9001/00	LBN9003/00

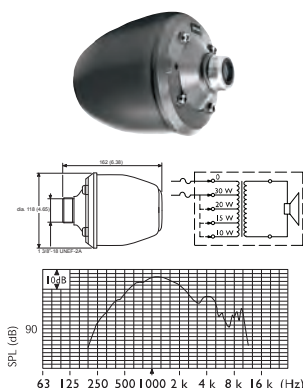

BOSCH DRIVER HORN FLARES - LBN SERIES

Flame-retardant, high-impact plastic for high strength and low weight, and are finished in light grey. A steel mounted bracket is also supplied.

Details	10" Round	15" Round	20" Round	9x15" x Square
Size	255mmØ	380mmØ	510mmØ	380x235mm
Code	LBC3403/16	LBC3404/16	LBC3405/16	LBC3406/16



BOSCH CABINET SPEAKER

General-purpose, cost effective loudspeaker for indoor use. Two brackets, fixed to the rear panel, are provided for quick and easy mounting on a wall or ceiling. The cabinet is available in the colours black or white. Sold as singles.

- Good speech intelligibility and background music reproduction
- Complies with international installation and safety regulations
- Mounting brackets for wall or ceiling mounting
- Finished in white or black
- MDF construction

Watt	9W			
Taps	1.5/3/6W			
Size	264x151x139mm			
SPL	91dB			
dBi	99dB			
Details	No Volume	No Volume	With Volume	With Volume
Colour	White	Black	White	Black
Code	LB1-UW06-L	LB1-UW06-D	LB1-UW06V-L	LB1-UW06V-D

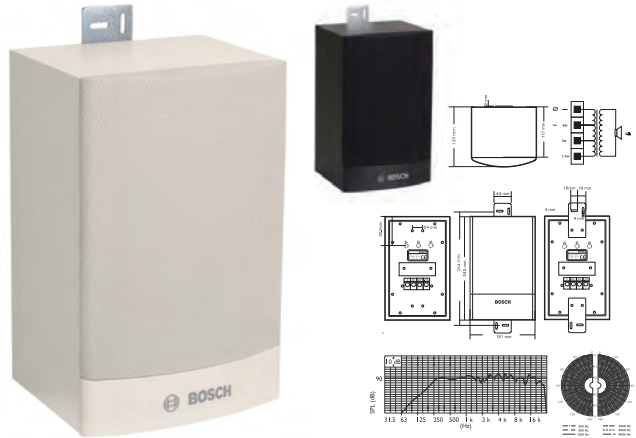

BOSCH CABINET SPEAKER

CORNER MOUNT

The LB1-CW06-x is a 6 W, general-purpose cost-effective loudspeaker for indoor use. Two brackets with keyholes, fixed on one side provide quick and easy mounting in corners between two walls, or between a wall and ceiling. The cabinet is available in black or white.

- Good speech intelligibility and background music reproduction
- Special shape for mounting in corners
- Available in black or white
- MDF construction
- Compliancy with international installation and safety regulation

Details	Wedge	
Watt	9W	
Size	240x151x138mm	
SPL	91dB	
dBi	99dB	
Taps	1.5/3/6W	
Colour	Light	Dark
Code	LB1-CW06-L	LB1-CW06-D

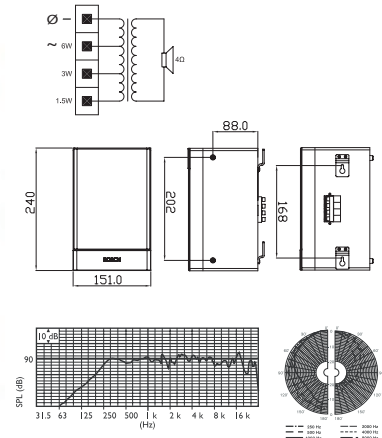

BOSCH PA HIFI SPEAKER

Premium sound cabinet loudspeakers are intended for clear reproduction of speech, foreground and background music to be used in general indoor and outdoor applications. Range consists of a 15 W and 30 W model, available in a light or dark colour. The loudspeakers have selectable 8 ohm, 70 V and 100 V inputs. Singles.

Details	4" Woofer ½" Tweeter		5" Woofer ½" Tweeter	
Watt	22.5W		45W	
Taps	1.9, 3.75, 7.5, 15W		3.75, 7.5, 15, 30W	
Size	205x136x117mm		250x160x140mm	
SPL	86dB		90dB	
dBi	98dB max		105dB max	
Colour	White	Charcoal	White	Charcoal
Code	LB2-UC15-L	LB2-UC15-D	LB2-UC30-L	LB2-UC30-D

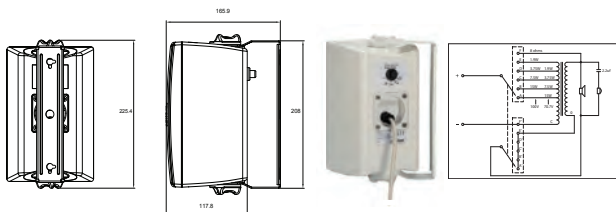



BOSCH XLA LINE-ARRAY LOUDSPEAKERS

LESS SPEAKERS FOR BETTER SOUND

The XLA 3200 range incorporates a unique technology angle. An ingenious new approach of positioning the loudspeaker drivers in the array, coupled with filtering techniques so each driver emits a dedicated frequency range, results in unique and advanced acoustical characteristics.

- Ideal combination of advanced acoustics and easy application
- Uniform distribution of natural sound throughout the room
- Extremely slim for unobtrusive, elegant, easy installation
- Excellent intelligibility of speech and music
- Suppressed side lobes reduces echos
- Suitable for both indoor and outdoor use
- Voice evacuation compliant as standard
- EN 54-24 and EN 60849 compliant

1200mm ARRAY FOCUSED

This loudspeaker, with its excellent directivity and high power output, can handle large (reverberant) indoor environments or outdoor use. Its full frequency range makes it ideal for music as well as speech reproduction. Conventional column loudspeakers produce a main lobe of sound, which is directed at listeners, and a number of unwanted side lobes. The LBC 3210/00 has highly suppressed side lobes in the vertical plane, resulting in a much clearer, less 'coloured' sound, even when close to the loudspeakers. This gives the line array loudspeaker superb intelligibility of both speech and music. 120cm high, 16 cm wide. 190Hz - 18KHz. Includes wall bracket. Optional floor stand.

Angle 1 kHz / 4 kHz (-6 dB)
 Horizontal 170° / 90°
 Vertical 55° / 18°

Details	Double Array
Watt	90W
Taps	15/30/60W
Size	1200x160x90mm
SPL	97dB
dBi	115dB
Code	LBC3210/00

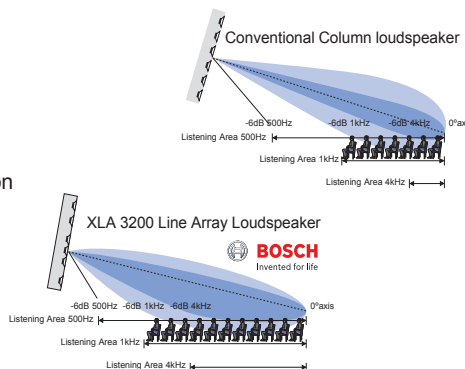
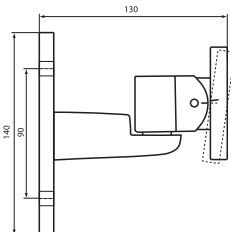

1200mm ARRAY

Offers extremely accurate directivity of sound. Ideal for medium and large (reverberant) environments as well as more acoustically demanding situations like buildings with pillars or exhibition halls full of stands. Gives excellent quality reproduction of speech and background music. Excellent directivity and side lobe suppression. 120 cm high, 8 cm wide. Includes wall bracket. Optional floor stand.

Angle 1 kHz / 4 kHz (-6 dB)
 Horizontal 210° / 132°
 Vertical 50° / 22°

Details	Full Array
Watt	90W
Taps	15/30/60W
Size	1200x80x90mm
SPL	92dB
dBi	110dB
Code	LBC3201/00



600mm ARRAY

A very compact loudspeaker that provides superb, clear sound in small- and medium-sized indoor venues like showrooms, canteens and meeting rooms. A really good performer with a superb size/performance ratio. Surprisingly clear and natural speech and music. 190Hz - 18KHz. Includes wall bracket. Optional floor stand.

Angle 1 kHz / 4 kHz (-6 dB)
 Horizontal 220° / 130°
 Vertical 70° / 18°

Details	Compact
Watt	45W
Taps	7.5/15/30W
Size	600x80mm
SPL	91dB
dBi	106dB
Code	LBC3200/00



FLOOR STAND

This universal floorstand provides an effective mounting solution. They are manufactured and finished to the same high standards as all Bosch products, assuring excellent quality and guaranteed compatibility throughout the range.

The LBC 1259/00 floorstand is hand-adjustable using a spring-loaded locking screw for heights between 1.4M-2.2M. An extra safety bolt on the support can be tightened to ensure the stand remains extended. This lightweight stand has a double-braced folding base for extra strength, and a wide leg span to ensure stability.

Details	Optional Stand
Size	1.4-2.2M
Code	LBC1259/00

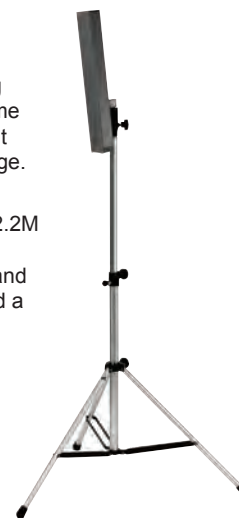

STAND CARRY BAG

For storage and ease of transport with two inside compartments with separate zippers for holding two universal floorstands (LBC 1259/00). Made from sturdy black weather-proof nylon.

Details	Suit LBC1259/00
Code	LM1-CB



BOSCH PENDENT SPEAKER

Sound spheres are pendent sound projectors designed to be suspended from the ceiling by their connecting cables. Their excellent sound spread makes them ideal for use in buildings with high ceilings, such as markets and superstores. The LS1-UC20E-1 is a powerful 20 W pendent sphere loudspeaker, intended for high quality speech and music reproduction. The state-of-the-art design is matched to both modern and traditional style environments. The loudspeaker is suitable for use in voice evacuation systems.

- Superb speech and music reproduction
- 5 m connection cable
- Provision for optional safety cord
- Water and dust protected to IP 65
- BS 5839-8 and EN 60849 compliant

Details	Omnidirectional
Watt	30W
Taps	2.5/5/10/20W
Size	254x185mmØ
SPL	86dB
dBi	99dB
Code	LS1-UC20E-1

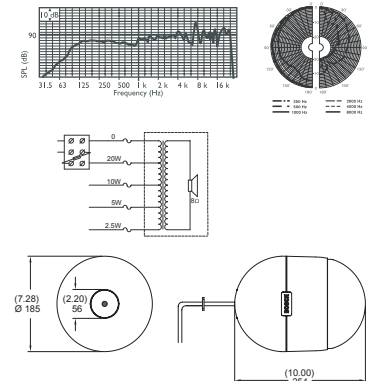

BOSCH SOUND PROJECTOR

The LP1-BC10E-1 is a powerful 10 W bidirectional sound projector intended for high quality speech and music reproduction in indoor and outdoor applications. The two Loudspeakers facing in opposite directions are ideally suited to applications such as tunnels, long corridors and shopping arcades. The state-of-the-art design is matched to both modern and traditional style environments. The sound projector is suitable for use in voice alarm systems.

- Superb speech and music reproduction
- Integrated connection cable
- Ceiling or wall mounting
- Water and dust protected to IP 65
- BS 5839-8 and EN 60849 compliant

Details	Bidirectional
Watt	15W
Taps	1.25/2.5/5/10W
Size	300x185mmØ
SPL	80dB
dBi	90dB
Code	LP1-BC10E-1

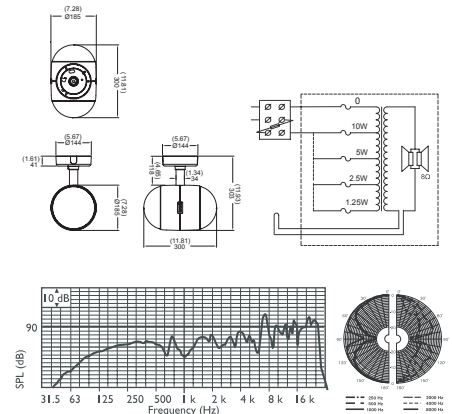

BOSCH SOUND PROJECTOR

The LP1-UC10E-1 is a powerful, 10 W sound projector intended for high quality speech and music reproduction in indoor and outdoor applications. The state-of-the-art design is matched to both modern and traditional style environments. The sound projector is suitable for use in voice alarm systems.

- Superb speech and music reproduction
- Integrated connection cable
- Ceiling or wall mounting
- Water and dust protected to IP 65
- BS 5839-8 and EN 60849 compliant

Details	Unidirectional	
Watt	15W	30W
Size	1.25/2.5/5/10W	2.5/10/20W
SPL	86dB	87dB
dBi	96dB	100dB
Code	LP1-UC10E-1	LP1-UC20E-1

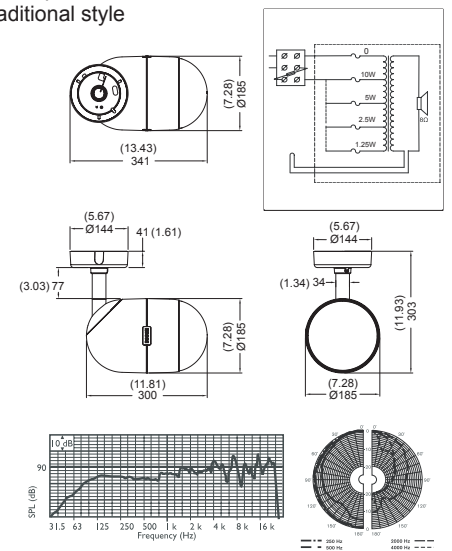



BOSCH PENDENT SPEAKER

The LBC 3095/15 is a pendant sphere designed to be suspended from the ceiling via its connecting cable. The pleasing shape and neutral colour make the pendant sphere models interesting architectural features in their own right.

- Suitable for speech and music reproduction
- Simple power setting
- 5 m fixed connection cable
- Splash-waterproof type
- Robust self-extinguishing ABS enclosure to UL 94 V0

Details	Omni-Dirrectional
Watt	15W
Taps	2.5/5/10W
Size	157x185mmØ
SPL	89dB
dBi	99dB
Code	LBC3095/15

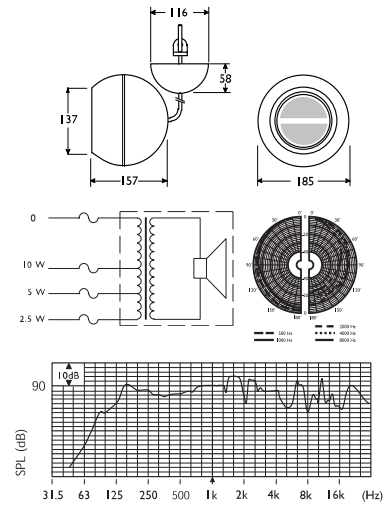

BOSCH SOUND PROJECTOR

UNI-DIRECTIONAL

The LBC 3432/02 is a powerful 20 W sound projector intended for speech and music reproduction in indoor and outdoor applications. The sturdy, aluminum enclosure is finished in the colour off-white. It has provisions for cable loop through connection and mounting of a line or loudspeaker supervision board. The sound projector is suitable for use in voice alarm systems.

- Excellent speech and music reproduction
- Provision for supervision board mounting
- (Suspended) ceiling and/or wall mounting
- Water and dust protected to IP 66
- EN 54-24 certified

Details	Unidirectional
Watt	30W
Size	200x146mmØ
SPL	92dB
dBi	105dB
Code	LBC3432/02

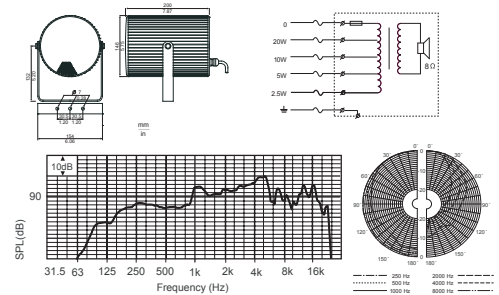

BOSCH SOUND PROJECTOR

BI-DIRECTIONAL

The LBC 3430/02 is a 12 W bidirectional sound projector intended for speech and music reproduction in indoor and outdoor applications. The two loudspeakers facing in opposite directions are ideally suited to applications such as subway tunnels, long corridors and shopping arcades. The sturdy, aluminum enclosure is finished in the colour off-white. The sound projector is suitable for use in voice alarm systems.

- Excellent speech and music reproduction
- Ceiling and/or wall mounting
- Robust aluminum extrusion enclosure
- Water and dust protected to IP 55
- BS 5839-8 and EN 60849 compliant

Details	Bidirectional
Watt	18W
Taps	1.5/3/6/12W
Size	186x146mmØ
SPL	91dB
dBi	102dB
Code	LBC3430/02

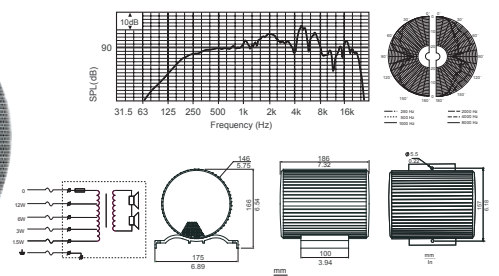

→ **Electro-Voice**

EVID CEILING SPEAKERS

EV Electro-Voice

The Electro-Voice EVID Ceiling loudspeaker system is a complete package consisting of a bezel assembly, grille, rear enclosure, coax mounted two-way loudspeaker and internal line-matching transformer. Features a waveguide coupled titanium coated dome tweeter, 2nd order crossover network at 3.3kHz, protection circuit to protect the network, woofer, and tweeter drivers from excessive power levels. Transformer with 70V or 100V lines, or 8Ω bypass. Selection is via a convenient switch on the front baffle. The perforated grille is finished in semi-gloss white powder coated enamel. The baffle and bezel are constructed from UL94V-0 rated ABS. The EVID line of ceiling speakers has been designed to provide wide dispersion, high efficiency, high-maximum output, ease of installation, and wide-range reproduction of music or voice.



EVID C4.2

4" TWO-WAY HI-FI 8" BEZEL PAIR

Perfect for conventional rooms. It has excellent bandwidth in an esthetically very unobtrusive installation profile. Its compact design fits in tight areas. Its 4-inch woofer and waveguide coupled, titanium-coated dome tweeter give smooth, wide frequency response. The enclosure is ported and tuned to provide surprising bass response in such a compact package. Features an easy 3-point mounting system for quick installations.

100mm Polypropylene Woofer
20mm Titanium Mylar Tweeter
70V: 1.88/3.75/7.5/15/30W
100V: 3.75/7.5/15/30W
Bypass: 8Ω (Front switch)
65Hz-20KHz -10dB 130°
UL1480, UL2043, UL94V-O

Watt 50W(200Wmax)
Taps 8Ω/1.88/3.75/7.5/15/30W
Size 176x181mmØ
SPL 85dB
dBi 109dB
Freq. 65Hz-20KHz
Code C4.2

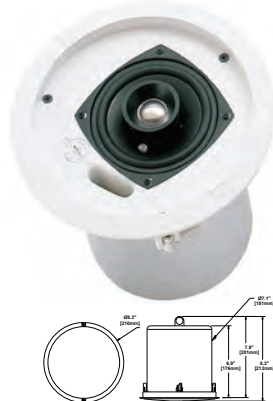

EVID C10.1 SUB-WOOFER

45Hz to 180Hz CEILING MOUNT

The C10.1 packs a 10-inch subwoofer in a tuned high performance enclosure to give amazing low frequency performance down to 45Hz! It is one of the few quick-mount ceiling TRUE subwoofers available. Flexible installation and powerful low-end performance make it the ideal mate to any EVID ceiling model.

- 10" High-Excursion sub
- Low Pass Network with Overload Protection
- Integrated low loss matching transformer allows for either 70v/100v or 8-ohm
- Tile bridge & mounting ring for easy installation

Watt 150W(600Wmax)
Taps 8Ω/7.5/15/30/60W
Size 303x320mmØ
SPL 94dB
dBi 120dB
Freq. 45Hz-180Hz
Code C10.1

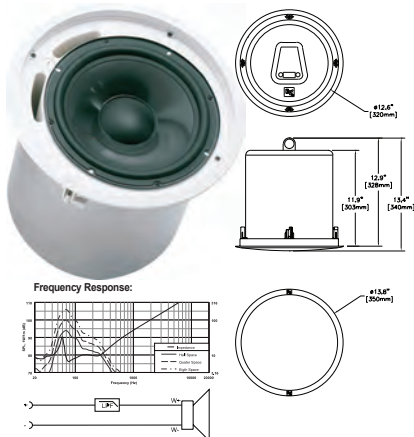

Sold in singles

EV Electro-Voice



EVID C12.2

- Full-range power, ample HiFi sound for high ceilings in large spaces
- High 100 dB sensitivity and high 100Wrms power-handling 12"
- Front-panel mode/wattage selector. White gloss perforated grille
- Safe, easy installation with included tile bridge and mounting ring
- Integrated transformer with automatic saturation compensation for distortion free 70 V, 100 V, or 8 Ω use
- Heavy-gauge steel enclosure
- Pendant Mount Rigging Points for use in Open Ceiling Installations
- Tile Bridge and Mounting Ring for Easy Installation into Tile Ceilings

Watt 100W(400Wmax)
Taps 8Ω/4/8/16/32/64W
Size 333x414mmØ
SPL 100dB
dBi 126dB
Freq. 65Hz-20KHz
Code C12.2



EVID C8.2

8" TWO-WAY HI-FI PAIR

Tuned enclosure 8-inch woofer to provide amazing bass response. The 1-inch waveguide-coupled tweeter give smooth controlled coverage out to 20 kHz. Perfect for installations where a flush-mount design is desired but demand for high-quality audio exists. Features a 4-point mounting system to make installations fast and easy. Available in a low-profile version, ideal for tight ceiling spaces.

200mm Polypropylene Woofer
25mm Titanium Mylar Tweeter
70V: 1.88/3.75/7.5/15/30W
100V: 3.75/7.5/15/30W
Bypass: 8Ω (Front switch)
50Hz-20KHz -10dB 110°
UL1480, UL2043, UL94V-O

Watt 75W(300Wmax)
Taps 8Ω/1.88/3.75/7.5/15/30W
SPL 91dB
dBi 116dB
Details Extended LF Low Profile
Freq. 50Hz-20KHz 55Hz-20KHz
Size 255x270mmØ 178x270mmØ
Code C8.2 C8.2LP



EVID C8.2 HIGH CEILING

8" TWO-WAY FOR HIGH CEILINGS

The EVID C8.2HC is ideal for high ceilings and reverberant "problem" rooms. Its exclusive ported, waveguide-coupled, 8" driver provides excellent intelligibility and definition. The 8.2HC's patent-pending design provides great coverage control throughout the voice range and above. No other ceiling speaker system provides the combination of excellent pattern control, wide bandwidth, high power handling, and compact design like the C8.2HC.

200mm Polypropylene Woofer
25mm Titanium Mylar Tweeter
70V: 7.5/15/30/60W
100V: 7.5/15/30/60W
Bypass: 8Ω (Front switch)
50Hz-20KHz -10dB 70°
UL1480, UL2043, UL94V-O

Watt 75W(300Wmax)
Taps 8Ω/7.5/15/30/60W
Size 303x320mmØ
SPL 93dB
dBi 118dB
Freq. 50Hz-20KHz
Code C8.2HC



Sold in pairs



→ **Electro-Voice**



EVID SURFACE MOUNT SPEAKERS

EVID is not just another speaker. From the unique aesthetic design to the innovative acoustic integrity, EVID delivers value, performance and ease-of-use to the contractor and end listener alike. EVID is something attractive and superior sounding in a world of plain black boxes. EV have achieved a comprehensive background/foreground speaker line with the characteristics installers need and the features users want.

- 1" titanium diaphragm HF driver with neodymium magnetic structure
- Coherent Coverage Waveguide
- Full-bandwidth overload protection (LF and HF)
- Elliptical weather-resistant ABS enclosure
- Oval shaped. Metal grilled. Modern styling.
- Paintable black or white finish
- Strong-Arm Mount™ for easy, flexible aiming
- "T" version for 70 or 100 V distributed systems
- Screw terminal inputs. Daisy-chain option
- Premium build quality and excellence in sound



EVID 3.2

Woofer	3½"			
Power	75Wrms (300Wmax)			
Size	135x130x165mm (1.5Kg)			
Freq.	85-20KHz			
SPL	87dB			
dBi	104dB			
Taps	8 Ohm	8Ω/70V/100V		
Colour	Black	White	Black	White
Code	EVID3.2	EVID3.2W	EVID3.2T	EVID3.2TW

Includes wall stand. Sold in pairs.
 Coverage -6dB Horz. 140° Vert. 100°
 Screw terminal back panel.
 0.75" Titanium tweeter
 Taps* 70V:5W, 100V:10W



EVID 4.2

Includes wall stand. Sold in pairs.
 Coverage -6dB Horz. 120° Vert. 80°
 Screw terminal back panel.
 1" Titanium tweeter Coax mounted
 8 Ohm input with optional: Taps* 70V:7W, 100V:15W

Woofer	4"			
Size	310x175x216mm (4Kg)			
Freq.	65-20KHz			
Power	100Wrms(400Wmax)			
SPL	89dB			
dBi	115dB			
Taps	8 Ohm	8Ω/70V/100V		
Colour	Black	White	Black	White
Code	EVID4.2	EVID4.2W	EVID4.2T	EVID4.2TW



EVID 6.2

Includes wall stand. Sold in pairs.
 Coverage -6dB Horz. 100° Vert. 80°
 Screw terminal back panel.
 1" Titanium tweeter Coaxial Mounted
 8 Ohm input with optional: Taps* 70V, 100V:15/30/60W

Woofer	6"			
Size	420x230x300mm (5.3Kg)			
Freq.	62-20KHz			
Power	150Wrms(600Wmax)			
SPL	94dB			
dBi	122dB			
Taps	8 Ohm	8Ω/70V/100V		
Colour	Black	White	Black	White
Code	EVID6.2	EVID6.2W	EVID6.2T	EVID6.2TW



EVID ACCESSORIES

Optional extras available: See overleaf...

Description	Code
Horizontal Mount Desk Stand	HS-3
Mic Stand Adaptor Mount Kit	MA-3
Weatherised Terminal Cover	TC-4B
Weatherised Terminal Cover	TC-4W
Weatherised Terminal Cover	TC-6B
Weatherised Terminal Cover	TC-6W



<http://data.wescomponents.com/Speakers/EV/>
<http://data.wescomponents.com/Speakers/EV/EVID.pdf>

→ Electro-Voice
EV Electro-Voice

EVID 12.1
12" SUBWOOFER ADD-ON

- Supplemental 12" bass system for indoor speakers
- Satellite system type - No additional amp required
- High-excursion woofer with dual voice coil for L/R channels
- High sensitivity, high power-handling as with other EVID
- Crossed-over pass-thru for up to four satellite speakers
- Trapezoidal shape for corner enhanced horn efficiency
- Eyebolts for optional ceiling hang mounting by rigging
- Steel-reinforced cabinet with mounting hardware included
- Paintable black or white finish decor attractive

Woofer	12"
Power	175Wrms(700Wmax)
Size	412x594x305mm (18Kg)
Freq.	40-140Hz
SPL	100dB
dBi	128dB
Taps	8 Ohm x2
Colour	Black White
Code	EVID12.1 EVID12.1W

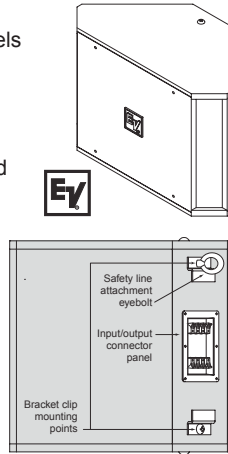
EVID FM SERIES
2-WAY FLUSH MOUNT LOUDSPEAKER

- Shallow profile, ideal for tight wall or ceiling spaces
- Tuned passive radiator extends bass, enhances performance
- High quality 1-inch titanium dome tweeter
- Full-bandwidth overload protection
- 70 V, 100 V, and 8 ohms operation
- Front-panel mode/wattage switch
- Fully-sealed enclosure provides superior isolation to protect adjacent rooms
- Secure Phoenix-style pass-through connectors for easy wiring and installation.
- Four point "quick mounting" tabs for fast attachment in any wall cavity
- Can-mounted transformer for enhanced rigidity
- Ribbed back can eliminates flexing

Woofer	4" + 4" PR	6" + 6" PR
Power	50Wrms(200Wmax)	75Wrms(300Wmax)
Size	350x200x95mm (3Kg)	465x256x100mm (6Kg)
Freq.	52-20,000KHz	52-20,000Hz
SPL	97dB	90dB
dBi	110dB	115dB
Taps	8Ω/1.75/3.75/7.5/15/30	8Ω/7.5/15/30/60
Colour	White	White
Code	FM4.2	FM6.2

EVID MIC STANDING
MICROPHONE STAND KIT

Clever system that attaches EVID speakers in between microphone holder and microphone stand (not included). Angle adjustable.

Code
MA-3

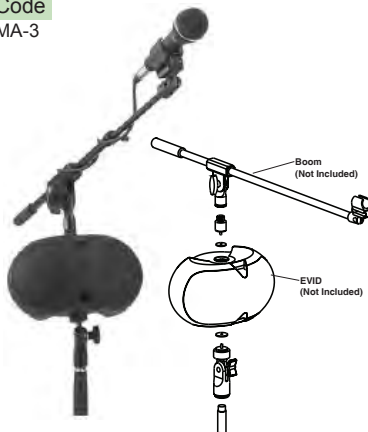
EVID DESK STAND
HORIZONTAL MOUNT

Suits all EVID Surface mount speaker boxes. Horizontal table-top mounting. Metal stand with rubber feet. Sold in pairs.

Code
HS-3

EVID BACK COVERS
WEATHER PROOF PLATE

Rugged terminal cover with cable grommet. Protects rear of EVID from the elements.

Suits	EVID4.2B	EVID4.2W	EVID6.2B	EVID6.2W
Colour	Black	White	Black	White
Code	TC-4B	TC-4W	TC-6B	TC-6W



**→ EV Wireless Mic R300****EV Electro-Voice****R300 WIRELESS MICROPHONE SYSTEM**

Designed for the entry-level professional, the Electro-Voice R300 makes the benefits of professional wireless microphone performance accessible to a new category of users. With features like one-touch ClearScan and EZsync transmitter update, the R300 offers professional-class capabilities but is as easy to setup and use as any entry-level wireless microphone system.

- ClearScan™ – find the clearest channel available with the touch of one button
- EZsync™ – infrared channel transfer from receiver to transmitter for easy and error-free setup
- PL22 cardioid dynamic microphone element for crisp, clear vocals in any application
- Rugged metal transmitters with backlit LCD display and battery gauge
- Bodypack with TA4 connector – Compatible with lapel and head-worn microphones
- 14-hour battery life from two AA alkaline batteries
- 32 preset channels, with compatible groups of 8 channels for simultaneous use
- Detachable half-wave TNC antennas enable use with APD4+ antenna distribution system
- Metal receiver chassis with optional rack-mount ears and front-mount antenna cables

**R300 HANDHELD SYSTEM****MIC & RECEIVER KIT**

The HT-300 metal handheld transmitter is made to withstand the rigors of daily use but still be comfortable in your hand. The PL22 dynamic microphone is the perfect all-around microphone for speaking engagements, singing and emcees. The cardioid pickup pattern rejects noises from the surroundings, helps control audio feedback, and still allows an experienced vocalist to work the microphone.

- ClearScan automatically finds the clearest channel
- EZsync one-step channel setup
- PL22 cardioid dynamic microphone element
- 14 hour battery life from two AA alkaline
- Rugged metal transmitter
- Metal receiver chassis

Code

R300-HD-B

**R300 LAPEL SYSTEM****MIC & RECEIVER KIT**

The R300-L system includes the metal BP-300 bodypack transmitter, which uses two AA batteries. With ClearScan and EZsync, the R300-L is the easiest wireless system you will ever use for presentations and worship services. The directional ULM18 helps to reject noise from the surroundings and control audio feedback.

- ClearScan automatically finds the clearest channel
- EZsync one-step channel setup
- ULM18 directional lapel microphone
- 14 hour battery life from two AA alkaline
- Rugged metal transmitter
- Metal receiver chassis

Code

R300-L-B

**R300 HEADSET SYSTEM****MIC & RECEIVER KIT**

The R300-E system includes the metal BP-300 body pack transmitter, which uses two AA batteries. The HM3 microphone is comfortable for extensive daily use, including long presentations. Using a headwork microphone helps to control audio feedback and provides consistent audio while the speaker moves naturally around the stage.

- ClearScan automatically finds the clearest channel
- EZsync one-step channel setup
- HM3 omni-directional microphone
- 14 hour battery life from two AA alkaline
- Rugged metal transmitter

Code

R300-E-B

**R300 ACCESSORIES**

Replacement microphones.

HANDHELD MIC

Code

HT-300-B

LAPEL MIC

Code

ULM18

HEADSET MIC

Code

HM3

BODY PACK

Belt pack transmitter (only).

Code

BP-300-B

BODY PACK SYSTEM

Kit includes the receiver unit and a belt body transmitter unit (TA4). No microphone.

Code

R300-BP-B

RECEIVER

Base station only.

Code

R300-RX-B



→ **Bosch Plena Easy Commercial PA**



BOSCH
Invented for life



BOSCH PLENA-EASY MIXER AMP

SINGLE ZONE WITH 100V LINE + 8Ω OUTPUT

High performance, professional public address units with modern state of the art features. They are easy to use, taking the complexity away from the user and putting it where it belongs, inside the equipment. Providing a crisp call or clear music is as easy as turning on the radio. The amplifier is also surprisingly affordable, without sacrificing features such as ducking, priority and flexibility.

- 4 microphone/line inputs, plus 3 music source inputs
- Telephone input with priority & VOX
- Announcement only output, 3-wire volume override
- Voice-activated emergency override
- Wide range of power (30, 60 and 120 Watts)
- 70 V / 100 V and 8 ohm outputs
- 2-tone chime (more with PLE4TM)
- Outputs for line out and music only out
- Unique easy-to-use intuitive tone controls



MIC.	Inputs	Zone	Insert	Output	Code
4	3xRCA	1	No	30Wrms	PLE-1MA030
4	3xRCA	1	No	60Wrms	PLE-1MA060
4	3xRCA	1	No	120Wrms	PLE-1MA120

<http://data.wescomponents.com/bosch/PLE-1MA.pdf>

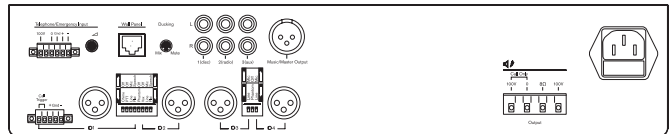

BOSCH PLENA-EASY MIXER AMP 2 ZONE

TWO ZONE WITH 100V LINE + 8Ω OUTPUT

The music can be switched on and off in the zones via the front panel and optional wall panel. Announcements from the PLE-2CS two-zone call station can be routed to zone 1 or zone 2, or both. Announcements from the tel/100 V input or inputs 1 & 2 are routed to both zones. Input 1 can be used for a PLE-1CS all-call call station or any other microphone or call station with a PTT contact.

- 6 microphone/line inputs plus 3 music source inputs
- Telephone and a call station input with priority & VOX
- 2 zones and announcement only output
- Voice activated emergency override
- High output power 120 and 240 Watts
- 70 V / 100 V and 8 ohm outputs
- 2-tone chime built in (7 more chimes optional with call station)
- Outputs for line out, music only out and insert point
- 24 V backup input with built in 24 V charger
- Separate tone controls for microphones and music sources



MIC.	Input	Zone	Insert	Output	Code
6	3xRCA	2	Yes	120Wrms	PLE-2MA120
6	3xRCA	2	yes	240Wrms	PLE-2MA240

<http://data.wescomponents.com/bosch/PLE-2MA.pdf>

BOSCH PLENA-EASY MIXER PRE-AMP

AMPS TO SUIT - NEXT PAGE...

The Plena mixer is a high performance, professional public address mixer with modern state of the art features. Combined with a power amplifier for an easy-to-operate powerful flexible public address system.

- 6 microphone/line inputs, plus 3 music source inputs
- Telephone and a call station input with priority & VOX
- 2 zones and 2-channel operation
- Voice-activated emergency override
- 2-tone chime built in, 7 more chimes optional with call station
- Outputs for line out, music-only out, and insert point
- 24 V backup input with built in 24 V charger
- Separate tone controls for microphones and music sources



MIC.	Input	Zone	Insert	Output	Code
6	3xRCA	2	Yes	Line	PLE-10M2

<http://data.wescomponents.com/bosch/PLE-10M2.pdf>



→ Bosch Plena Easy Commercial PA

BOSCH PLENA-EASY POWER AMPLIFIER

POWER AMP ONLY WITH 100V LINE + 8Ω OUTPUT

High-power plug-and-play cost effective power amplifiers that deliver 120 and 240 Watts to constant voltage or 8 ohm loads. Built with premium quality and protections, they offer basic functionality at a budget price. The amplifiers offer straight 1 V and 100 V line in, and 70 V, 100 V and 8 ohms out. They can extend the power of the PLE-series mixer amplifiers or be combined with the PLE-10M2-EU mixer, or work anywhere where more power on an existing 100 V line is needed or when a line level signal is provided.

- 120 and 240 W power amplifier in a compact housing
- 1 V line level balanced (XLR Loop-Through) input or...
- 100 V input for slave operation on 100 V speaker line
- 70 V, 100 V and 8 ohm outputs screw wire connect
- Forced front to back ventilation (directly stackable)
- 24 VDC backup power input with built in charger

Input	Output	Code
1	120Wrms	PLE-1P120
1	240Wrms	PLE-1P240

<http://data.wescomponents.com/bosch/bosch/PLE-1P.pdf>



BOSCH PLENA-EASY eWALL-PLATE

Wall Panel is used to remotely select a music source and activate or deactivate zones of a Plena PLE audio mixer or mixer amplifier.

- Can be used for all Plena Easyline (PLE) mixer amplifiers
- Remote selection of three music source inputs
- Remote zone selection
- Perfect companion to Bosch volume controls
- Daisy-chain of multiple wall panels
- Powered through the Plena system

Code
 PLE-WP3S2Z

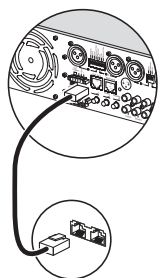

<http://data.wescomponents.com/bosch/PLE-WP3S2Z.pdf>

BOSCH PLENA-EASY eTONE GENERATOR

The Plena Tone Module is an extension to the Plena line of equipment, offering the user four different signals to use in an installation. The first two chimes are specifically made to comply with ISO 8201, which is mandatory in areas where installations are required to meet the AS2220.1.2 standard.

- Plena-Easy Evacuation, Alert, Time Signal, and Chime signal generation
- Microphone pre-amplifier connection with PTT
- Stereo line input with priority switchover
- Australian Standard AS2220.1.2 and ISO 8201
- Signal generation and line input without sacrificing an input of the mixer

Code
 PLE-4TM



<http://data.wescomponents.com/bosch/PLE-4TM.pdf>

eDESK-MIC HEAVY DUTY

- Sturdy desk top microphone for demanding applications
- PTT-key for calls for activation
- Momentary or toggle
- Green LED, indicating microphone active
- Stable metal base design
- 2 m cable
- Lockable Euro style connector
- Phantom powered by amplifier

Code
 PLE-1SCS

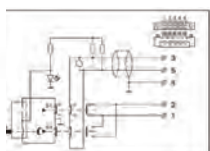

<http://data.wescomponents.com/bosch/PLE-1SCS.pdf>

eDESK-TOP MIC

- PTT-key for calls for activation
- Momentary or toggle
- Green LED, indicating microphone active
- Stable metal base design
- 2 m cable
- Lockable Euro style connector
- Phantom powered by amplifier

Code
 PLE-1CS

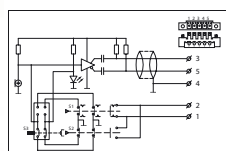

<http://data.wescomponents.com/bosch/PLE-1CS.pdf>

eDESK-TOP MIC 2 ZONE

- Modern two-zone call station for the PLE series
- Selectable gain
- Speech filter and limiter
- Output level control
- Loop-through option for up to 8 call stations
- LED indications for zone selection, busy, and power on

Code
 PLE-2CS

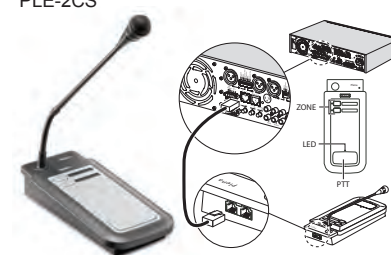

<http://data.wescomponents.com/bosch/PLE-2CS.pdf>

→ **Bosch Plena PA**



PLENA PUBLIC ADDRESS SOLUTIONS

Plena Solutions can be used to tailor the public address system to the precise needs of small-to-mid-sized locations. Plena offers facilities for background music, paging and playing pre-recorded commercials and additional power for applications such as hotels, offices and shopping malls.

- High quality sound and construction
- Ideal for small-to-midsized applications
- Easy expandability and function
- Easy to install and maintain

<http://products.boschsecurity.com.au>



PLENA MIXER AMP ALL-IN-ONE

DVD/CD/MP3/AM/FM/MIC MIXER AMP WITH 100V LINE + 8Ω OUTPUT

Versatile all-in-one solution to cover all needs for background music (BGM), making announcements and paging people. This high performance yet affordable unit is very easy to install and operate. It is typically used in shops, supermarkets, restaurants, bars, schools, canteens, gyms, garages and other places where BGM creates the right atmosphere, and also amplified speech needs to be heard clearly.

- All-in-one solution for background music and paging
- DVD/CD-player for video and audio
- Supports MP3, JPEG, and multi-format video outputs
- FM/AM tuner with 10 presets and digital control
- Dual-zone 120 W mixer amplifier with volume control per zone
- 70V / 100V and 8 ohm outputs
- Selectable priority and VOX switching on microphone input 1
- Optional 2-tone chime to precede announcements
- Remote control



MIC. Input	Zone	Insert	Output	Details	Code
3	2xRCA	2	No	120Wrms DVD + AM/FM	PLN-2AIO120

<http://data.wescomponents.com/bosch/PLN-2AIO120.pdf>

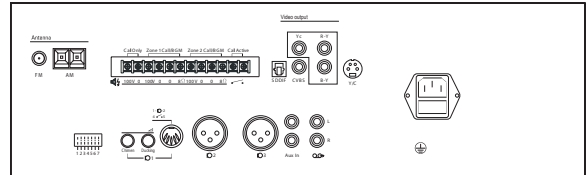
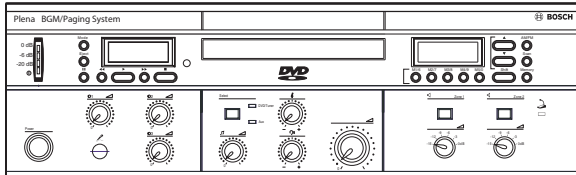

PLENA INDUCTIVE LOOP AMP

The Plena Loop Amplifier is a cost-effective amplifier designed to drive a wire loop installed in the floor or ceiling, covering an area of up to 600M² per amplifier. This solution enables hearing-aid users in the area enclosed by the wire loop to hear all announcements, or music. Hearing-aid users can set their devices to the Tmode setting to receive the signal coming from the loop. They receive announcements in excellent audio-quality, without the background noise or reverberations that normally impair intelligibility for people with hearing disabilities.

- High power, current driven amplifier
- Two microphone/line inputs, one priority input (100 V)
- Selectable frequency range and tone controls
- Limiter and automatic gain control (AGC)
- Integrates in an EN 54-16 and EN 60849 compliant system

Code
PLN-1LA10



<http://data.wescomponents.com/bosch/PLN-1LA10.pdf>

INDUCTION LOOP TESTER

The Plena inductive loop receiver is a compact, portable device intended to receive the field from an inductive loop for assistive listening device users. It can be used to monitor the field strength and quality of the inductive loop system such as from the Bosch Plena PLN1LA10.

- Monitoring of an inductive loop system
- Quick check of field strength
- Neck cord included for use by assistive hearing device users without "T" setting.
- Earphones included
- For two AAA rechargeable or alkaline batteries



Code
PLN-ILR



<http://data.wescomponents.com/bosch/PLN-ILR.pdf>

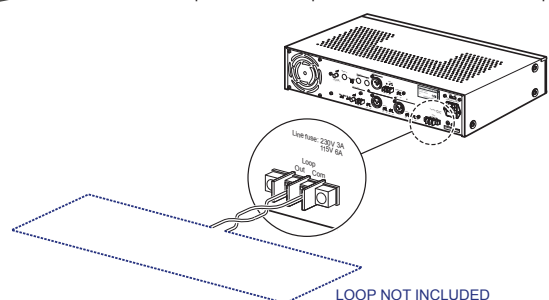

LOOP NOT INCLUDED



→ **Bosch Plena PA**

PLENA MIXER AMPS

100V LINE + 8Ω OUTPUT

The Plena mixer amplifier is a versatile, high-performance unit with four mono microphone inputs and a music input. It fulfills a wide variety of public address requirements at a surprisingly low cost.

- Range of single zone mixer amplifiers from 30W to 120W
- 70V / 100V and 8 ohm outputs
- Four low-noise balanced inputs for microphone or line
- Selectable priority & VOX switching on microphone input 1
- Optional 2-tone chime to precede announcements
- VOX activated emergency override
- Outputs for normal, call-only and mix-only zones
- Select switch for CD, tuner or auxiliary music inputs



MIC. Inputs	Zone	Insert	Output	Code
4	3xRCA 1	Yes	30Wrms	LBB1903/10
4	3xRCA 1	Yes	60Wrms	LBB1906/10
4	3xRCA 1	Yes	120Wrms	LBB1912/10

<http://data.wescomponents.com/bosch/LBB19xxMA.pdf>

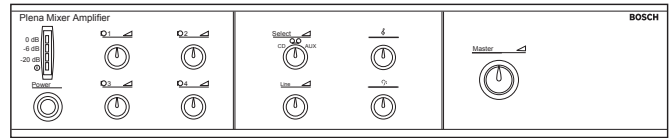
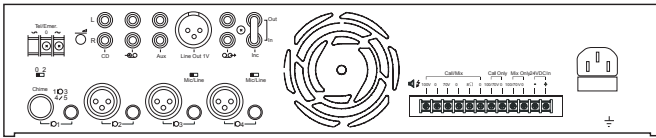

PLENA MIXER 6 ZONE PRE-AMP

PRE-AMPLIFIER ONLY - REQUIRES AMP

The Plena system pre-amplifier is a versatile, high performance unit with call and mono BGM (background music). It fulfills a wide variety of public address requirements at a surprisingly low cost. It can provide dual channel operation for simultaneous calls and BGM for up to six different zones, using two Plena amplifiers.

- Six-zone system pre-amplifier, with single or dual channel operation
- Two input channels for call stations
- Universal input for microphone/line, with speech optimized tone control
- Three inputs for BGM selection and music optimized tone control
- Front panel zone selection for BGM and call station zone selection for calls
- PC and trigger inputs for automated calls, alarm tones and chimes to selected zones



LBB1941-00 / LBB1946-00
 Microphone Not Included

MIC. Input	Zone	Insert	Output	Code
2	3xRCA 6	No	Line	LBB1925/10

<http://data.wescomponents.com/bosch/LBB1925-10.pdf>

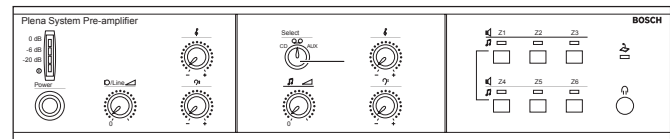
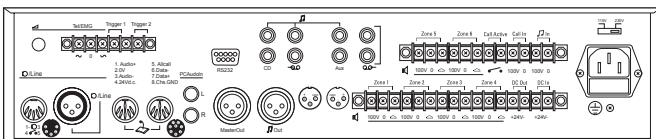

PLENA POWER AMPS

POWER AMPLIFIER ONLY WITH 100V LINE + 8Ω OUTPUT

A powerful range of power amplifiers in a 2U high 19" case for rack mounting or tabletop use. LEDs on the front panel show the status of the amplifier: power, audio output level, and supervised functions. This high-performance unit fulfills a wide range of public address requirements at a surprisingly low cost.

- High power amplifier in a compact housing
- 70V / 100V and 8 ohm outputs
- Dual inputs with priority switching
- 100 V input for slave operation on 100 V speaker line
- Temperature controlled forced front to back ventilation, directly stackable.

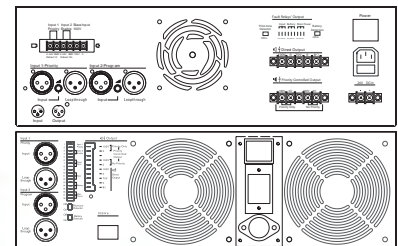

Input	Output	Code
1	120Wrms	LBB1930/20
1	240Wrms	LBB1935/20
1	480Wrms	LBB1938/20
1	1000Wrms	PLN-1P1000

<http://data.wescomponents.com/bosch/LBB1930-20.pdf>



→ **Bosch Source Accessories**



BOSCH
Invented for life



PLENA EASY BGM

Plena Easy Line SD Tuner BGM source is the ideal high-quality source for background music (BGM) in public address systems. It provides hours of uninterrupted music for professional systems. Designed without moving parts, it can be used in systems that are on for long periods. It is designed to be used with non-volatile steady state flash memory.

- MP3 playback from SD card and USB inputs
- FM tuner with RDS, presets and digital control
- Simultaneous operation of SD/USB-player and FM tuner
- Separate outputs for digital source and FM tuner

Code
PLE-SDT

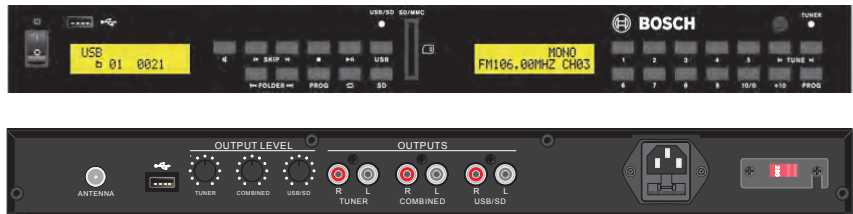

<http://data.wescomponents.com/bosch/PLE-SDT.pdf>

WEEKLY TIMER

The Plena Weekly Timer is an accurate timer for use in public address systems. It is ideally suited for schools, shopping malls and all other venues that need regularly timed messages, signals or other controls. It is ideally suited for connection to the Plena Message Manager and Voice Alarm System.

- Two weekly programs
- 14 Chimes
- Six contact outputs
- Automatic daylight/standard time
- BGM level control
- Hold and pause function
- Programming on the unit and via the supplied PC program
- Ideal partner complement to the Plena Message Manager and Voice Alarm Controller for timed messages

Code
PLN-6TMW



<http://data.wescomponents.com/bosch/PLN-6TMW.pdf>

DIGITAL MESSAGE ANNOUNCER

The Plena message manager is a high performance, highly versatile stand-alone digital message player. Applications range from spot announcements in supermarkets and theme parks to warning and evacuation messages in emergency situations.

- Highly flexible stand-alone digital message player
- Up to 12 messages and 12 trigger inputs
- Downloads messages from a PC in WAV format
- Compliant with standards for emergency sound systems
- Zone control for Plena system preamplifier LBB 1925/10
- Front panel control and remote control

Code
LBB1965/00



<http://data.wescomponents.com/bosch/LBB1965-00.pdf>

FEEDBACK ELIMINATOR

The Plena feedback suppressor uses a powerful DSP with a patented algorithm to suppress acoustic feedback. It actively filters out unwanted room reverberations using an echo-cancellation and de-reverberation algorithm. By adding masked (inaudible) noise to the output signal or by shifting the frequency of the output signal by five hertz, the Plena feedback suppressor is able to detect the reverb component of the signal and remove it before feedback occurs. This leaves the original signal intact.

- Patented feedback suppression algorithm
- Suppresses feedback before it occurs
- Automatically adapts to the acoustical situation
- Up to 12 dB additional gain before feedback occurs
- Balanced line or microphone input with phantom supply
- Second microphone input with automatic mixer

Code
LBB1968/00



<http://data.wescomponents.com/bosch/LBB1968-00.pdf>



→ Bosch Microphones



PLENA ALL-CALL STATION MIC

The Plena Call Station is a stylish, high-quality call station with a stable metal base design, a flexible microphone stem, and a unidirectional condenser microphone. Its purpose is to make calls to all zones (all-call) in a public address system built around the LBB 1925/10 system pre-amplifier. In addition to tabletop use, the special design enables the unit to be neatly flush-mounted in desktops.

- Stylish all-call call station, intended for LBB 1925/10 system pre-amplifier
- Unidirectional condenser microphone on flexible stem
- Momentary PTT-key for calls
- Selectable gain, speech filter, and limiter for improved intelligibility
- Stable metal base design
- Fixed 5 m cable and loop-through connector for additional call stations



Code
 LBB1941/00

<http://data.wescomponents.com/bosch/LBB1941-00.pdf>

PLENA CALL STATION

DESK MIC 6 ZONE

Six-zone Call Station is a stylish, high-quality call station with a stable metal base design, a flexible microphone stem, and a unidirectional condenser microphone. It can make calls to selected zones (one to six and all-call) in a public address system built around the LBB 1925/10 system pre-amplifier. In addition to tabletop use, the special design enables the unit to be neatly flush-mounted in desktops.

- Stylish six-zone call station, intended for LBB 1925/10 system pre-amplifier
- Unidirectional condenser microphone on flexible stem
- Six zone selection keys, all-call key, and momentary PTT-key for calls
- Selectable gain, speech filter, and limiter for improved intelligibility
- Selectable priority levels and different pre and postcall chimes
- LED indications for zone selection, system activity, and call station status



Code
 LBB1946/00

<http://data.wescomponents.com/bosch/LBB1946-00.pdf>

UNIVERSAL TABLE TOP MIC

The Plena tabletop microphone is a stylish, high quality tabletop unidirectional condenser microphone, mainly intended for making calls in a public address system. Its heavy metal base and rubber feet ensure stability on any flat surface. The special design also allows the unit to be neatly flush-mounted in desktops.

- Stylish tabletop unidirectional condenser microphone on a flexible stem
- Phantom powered by amplifier
- Momentary or toggle PTT-key for calls with priority contact
- Green LED, indicating microphone active
- Stable metal base design with fixed 2 m cable
- Lockable DIN connector
- XLR Adaptor



Code
 LBB1950/10

<http://data.wescomponents.com/bosch/LBB1950-10.pdf>

UNIVERSAL HAND-HELD MIC

This unidirectional handheld microphone provides some motion freedom. It is based on a dynamic transducer element in a sturdy housing with shielding against wind and wind bursts (pops). The microphone has excellent cardioid directivity, greatly reducing acoustic feedback. The microphone is intended for public address and sound reinforcement applications such as in leisure centres, assembly halls, and shops. Includes wall mount clip. 221x53mm 420g. Bosch branded.

- Dynamic transducer 600 ohm 2mV/Pa
- Unidirectional handheld microphone
- High speech intelligibility 100Hz-13KHz
- Rugged construction - Dark grey finish
- Inbuilt mute I/O switch with PTT contacts
- 0.5M coiled / 1.2M uncoiled to 5 Pin Din



Code
 LBB9099/10

<http://data.wescomponents.com/bosch/LBB9099-10.pdf>

UNIVERSAL GOOSENECK MIC

The gooseneck microphone is a stylish high quality unidirectional condenser microphone, mainly intended for public address applications.

- Unidirectional condenser microphone
- Flexible stem
- Phantom powered by amplifier
- On/off sliding switch with priority contact
- Supplied with fixed 2 m (78 in) cable and lockable DIN connector



Code
 LBB1949/00

<http://data.wescomponents.com/bosch/LBB1949-00.pdf>

UNIVERSAL HEAVY-DUTY MIC

Professional Gooseneck Paging Microphone suitable for applications where ruggedness, dependability and durability are required - perfect for supermarkets!

- Durable single-zone gooseneck paging microphone with normally-closed preconfiguration
- Omnidirectional pickup pattern, speech-optimized frequency response
- Flexible 16" steel gooseneck arm

Code
 SR785LN/O

<http://data.wescomponents.com/bosch/SR785LN-O.pdf>



UNIVERSAL PTT HAND MIC

Dynamic passive handheld microphone push-to-talk is designed for close talking applications, and is ideal for short announcements.

- Excellent speech reproduction
- Rugged construction
- Easy to handle
- Remote switching contact
- Close talking applications
- Matt black finish

Code
 LBB9080/00

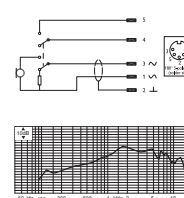

<http://data.wescomponents.com/bosch/LBB9080-00.pdf>



→ **Bosch Plena Matrix**



BOSCH
Invented for life



PLENA MATRIX DIGITAL SOUND SYSTEM

HIGH PERFORMANCE DSP WITH MULTIPLE CONTROL OPTIONS

The PLENA matrix system combines superior audio performance and product quality in an easy to install and use package. Ideal for recorded or live music and speech distribution, PLENA matrix will produce outstanding sound in small to medium applications requiring up to 8 zones.

- Complete DSP 8-zone matrix mixer and loudspeaker processor featuring powerful control
- 4 microphone/line inputs, call station input, 3 RCA music inputs and up to 8 mixed outputs
- 4-channel power amplifiers (100 V / 70 V / 8 Ω / 4 Ω output) with DSP processing and input mixing
- Standby mode engaged manually, or automatically with motion sensors in each zone
- Control via Windows PC GUI, Apple iOS App and Wall Control Panels
- 8-zone call station with capacitive touch buttons and programmable zone selection
- Three year warranty

www.wescomponents.com/bosch



INTELLIGENT FEATURES & SUPERB PERFORMANCE

As expected from Bosch, audio performance is premium and with their new PLENA matrix series, PA is now in the digital age of convenience with DSP and touch control.

- **8-Zone DSP Matrix Mixer** delivers a full-featured DSP zone matrix with 4 microphone/line, 3 music source, call station and emergency inputs, all output via parametric EQ to 8 zones.
- **4-Channel DSP Power Amplifiers** (125 or 220 W/channel models) Class D power amplifier, 100 V/70 V/8 Ω/4 Ω outputs. Built-in DSP with input mixing controls via iOS app or PC GUI. 8-band parametric EQ for each zone.
- **Call Station** with up to 8 Zones for paging.
- **Wall Control Panels** for simple volume and source select
- **Ethernet** for integration of computer and tablet devices for access to advanced signal administration and DSP audio control.



EASY CAT5 CONNECTIONS SOLUTIONS

Utilising CAT5 cabling dramatically reducing cable runs and installation time while simplify wiring chaos making setup and trouble shooting intuitive. Bosch recommend using CAT5e-SFTP Shielded Patch cables.

- **Amp Link CAT5e** connections link the DSP mixer with the amplifiers. 4CH per CAT5-SFTP Digital streaming up to 500 metres.
- **Call Station CAT5** connection can be Daisy-chained to expand to further call stations, audio, control and powered over a single CAT5.
- **RS485 CAT5** connection to Wall Controllers. Daisy-chain to expand to up to 16 wall controllers, all powered over CAT5.
- **Ethernet CAT5** to up to 5x PC Control and/or a wireless hub for WiFi control by up to 8 iPad/iPhone Apps for hand-held touch control.
- **Multiple systems** CAT5 Ethernet hub can connect further PLM-8M8 Matrix Mixers for easy central control of complex installations.

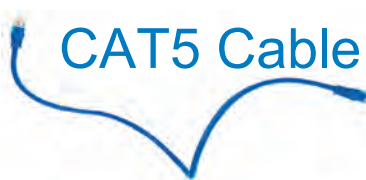

SAVE ON RUNNING COSTS

Class D Amplifiers are the most efficient form of amplification saving on long term power use. Amplifiers automatically drop into low power consumption mode when zones are not used. With the aid of optional PIR motion detectors, zones can automatically switch on and off. Reduce running costs and extending product life without depending on venue staff.



ADVANCED DIGITAL CONTROL

Taking advantage of the latest in GUI control of Digital Signal Processing makes advanced intricate control easy for even the novice. 3 Levels of operator are available. From simple venue employee to manager to advanced system with full DSP adjustments. Modern interfaces make operation intuitive and a joy to use.

- **Wall Control Panels** enable input source and volume control within each zone.
- **Call Stations** provide paging capability to up to 8 zones with optional ducking.
- **PC GUI** provides extensive controls for audio professionals and system admins with password protected access. Modern software is highly graphical and easy to use.
- **iOS App** for iPhone and iPad allows wireless control of input source and acoustic variables over multiple zones. Up to 8 users simultaneously can have portable access.

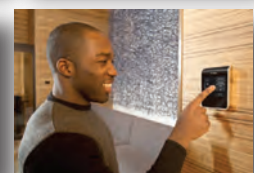



→ Bosch Plena Matrix

PLENA MATRIX DSP MIXER

8 ZONE CONTROLLER WITH 4 MIC & 3 BGM INPUTS + CALL STATION & CONTROL PANEL INPUTS

Multi-zone control centre for low-level mixing and routing of various sources. Required to integrate call stations, control panels, amplifiers, ethernet control. Inputs include 4x mic/aux, 3x RCA, 1x Call station, Phoenix EVAC terminal. Outputs to "Amp-link" RJ45 (x2) or (8x) 3-Pole Phoenix line level connectors.

- Independent zone selection (up to 8 zones)
- Independent mixing of 4 x mic/line inputs (per zone)
- Independent 3 BGM source selection (per zone)
- Paging level control per zone. Ducking facility
- Input gain, HPF, PEQ (5 filters mic/line)
- Dynamic range compressor. Dynamic bass.
- Crossover (HPF, LPF, up to 8th order)
- Output PEQ (7 filters per output)
- Output delay (up to 120 ms)
- Output level control with phase inversion
- Call station, override and tones facility

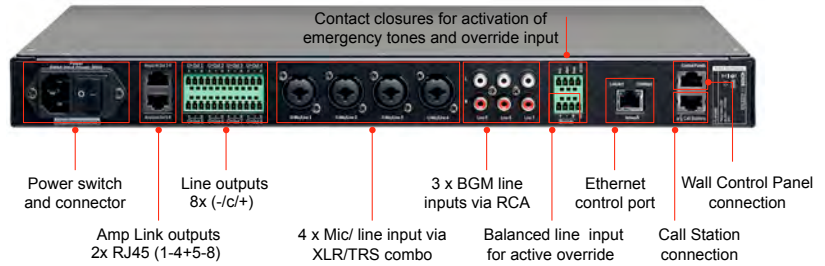

Code
 PLM-8M8

PLENA MATRIX DSP AMPLIFIERS

QUAD CHANNEL CLASS-D AMPLIFIERS WITH 4 LOCAL INPUTS

Can operate as a 4 zone amplifier or bridge to operate as a single zone high power stereo amplifier. 4CH inputs accept line-level or microphone, 1/4" or XLR or hard wired connections, level trimming. Sensor trigger inputs for auto stand-by power up/down. Use as part of an expanded system or stand-alone with full featured IP control.

- Highly efficient Class D amplifiers with low standby power
- Bridgeable outputs (1-2/3-4) for quad or stereo output
- Separate dedicated 4Ω / 8Ω / 70V / 100V on each output
- Level control of amplifier output channels via IP controlled
- Built-in DSP feature set and full 4-channel mixer. Dynamic bass.
- Standby on/off (Auto Standby with optional motion detectors)
- Crossover Filters and EQ Filters (PEQ, HPF, LPF, Shelf)
- Delay control up to 120 ms delay per channel with distance
- Dynamic range compressor/limiting with advanced controls
- Local OVERRIDE connection for emergency, EVAC, etc.

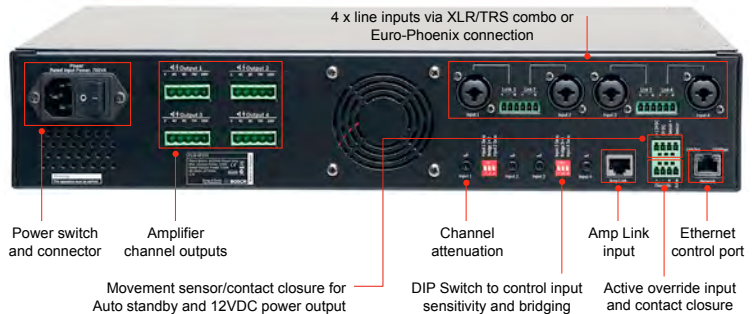

Outputs Bridged Code
 4x 125W 2x 250W PLM-4P125
 4x 220W 2x 445W PLM-4P220

www.wescomponents.com/bosch

PLENA MATRIX CALL STATION

8 ZONE ANNOUNCING MICROPHONE

- Paging any combination of 8 zones
- Capacitive touch buttons
- Status LED indicators
- Label inserts printed from PC GUI
- Powered via CAT5 from PLM-8M8
- Daisy chained using CAT5 RJ45

Code
 PLM-8CS

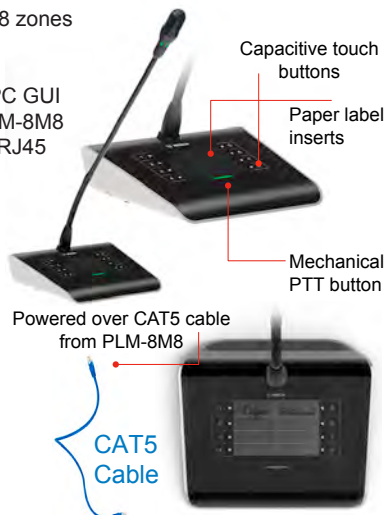

PLENA MATRIX WALL CONTROL PANEL

IN-ZONE CONTROLLER

- Individual local zone controller
- Volume & input source selection
- Status LEDs & Volume level
- Label inserts printed from PC GUI
- Powered via CAT5 from PLM-8M8
- Daisy chain more units with CAT5

Code
 PLM-WCP

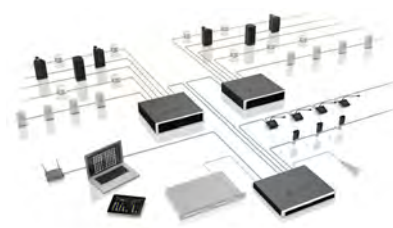

www.wescomponents.com/bosch



→ Bosch Commercial Electronics

BOSCH
 Invented for life

BOSCH

Invented for life

A PRACTICAL SOLUTION FOR ALL TYPES OF APPLICATIONS

With more than 60 years of experience in the design and development of electro-acoustic technology, Bosch is an established leader in the field. Their guiding principle is to create products that are superior in terms of technology, design and ease of use. From waveguide to array technology, and 3-D simulation to cutting edge design, Bosch's acoustical expertise is as extensive as it is innovative. Turning comprehensive experience into world-class acoustical solutions – that's how Bosch continues to lead the way.

Enabling optimal acoustics

At Bosch, our expertise is in developing superior technology for an optimal acoustical environment. Sometimes this means high quality background music with a consistent sound level everywhere in the listening area. Other times, as in the case of an emergency, it means messages which are received clearly, with high speech intelligibility – even when there is considerable background noise. It's all made possible through the technologies developed by Bosch: cardioid column loudspeakers, feedback suppression, reverberation technology, and many others. And Bosch continues to innovate, creating today's technologies which will become tomorrow's industry standards.

Investment in R&D

Bosch's reputation for producing state of the art technologies is largely due to the extensive research that it invests in. Its commitment to innovation is huge: Bosch owns and operates one of Europe's largest acoustical test and measurement facilities. This test centre has 5 fully equipped anechoic rooms, allowing Bosch to accurately and automatically measure microphones and loudspeakers. Extensive testing, all done according to internationally recognised industry standards, ensures that customers can be confident about the high quality of every Bosch acoustical product.

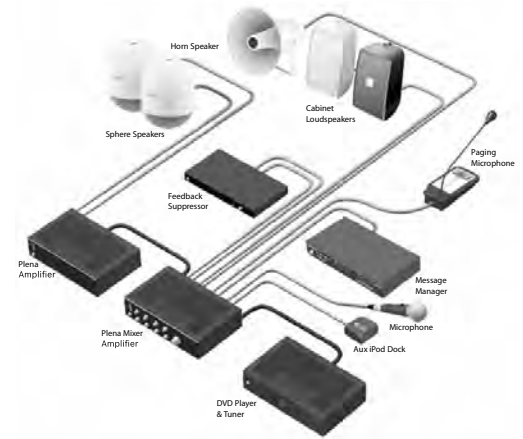
Plena Matrix Digital Sound System

Code	Description
PLM-8M8	PLENA matrix 8CH DSP Matrix Mixer
PLM-4P125	PLENA matrix DSP Quad Power Amplifier 125W
PLM-4P220	PLENA matrix DSP Quad Power Amplifier 220W
PLM-8CS	PLENA matrix 8 Zone Call Station
PLM-WCP	PLENA matrix Wall Control Panel

 Plena Matrix Software:
 Windows & iOS

Plena Easy Amplifiers

Code	Description
PLE-1CS	Plena e desk mic gooseneck - all call
PLE-1MA030	Plena easy 30w mixer amp 4x inputs
PLE-1MA060	Plena easy 60w mixer amp 4x inputs
PLE-1MA120	Plena easy 120w mixer amp 4x inputs
PLE-1P120	Plena easy power amp 120w
PLE-1P240	Plena easy power amp 240w
PLE-1SCS	Plena e heavy duty desk mic gooseneck - all call
PLE-2CS	Plena e desk mic gooseneck - 2 zone
PLE-2MA120	Plena easy 120w 2 z mixer amp 6x inputs
PLE-2MA240	Plena easy 240w 2 z mixer amp 6x inputs
PLE-4TM	Plena e tone generator module
PLE-10M2	Plena easy mixer 2 channel 6x input
PLE-WP3S2Z	Plena e wall panel source selector

Plena Mixer Amps

Code	Description
LBB1903/10	30 watt mixer amp, 100v line, includes rack ears
LBB1906/10	60 watt mixer amp, 100v line, includes rack ears
LBB1912/10	120 watt mixer amp, 100v line, includes rack ears
PLN-	"All in One" 2 zone 120 watt mixer amplifier with built in CD/MP3
2AIO120	/DVD player and AM/FM tuner. This

Plena Power Amps

Code	Description
LBB1930/20	120 watt power amplifier, includes rack ears
LBB1935/20	240 watt power amplifier, includes rack ears
LBB1938/20	480 watt power amplifier, includes rack ears
PLN-1P1000	1000 watt power amplifier, includes rack ears

Loop Amps

Code	Description
PLN-1LA10	Loop amplifier, delivers 10 amps into the loop making it suitable for covering up to 600 square metre
PLN-ILR	Plena Inductive Loop Receiver / basic test set including headphones

Mixers

Code	Description
LBB1925/10	"Plena" system preamp / mixer, 6 zone paging system, includes rack ears

Microphones

Code	Description
LBB1941/00	"Plena" all-call desktop condenser microphone / call station for LBB1925/10
LBB1946/00	"Plena" 6 zone desktop condenser microphone / call station for LBB1925/10
LBB1949/00	Permanently installed gooseneck microphone, 395mm, dynamic
LBB1950/10	Universal desktop condenser paging microphone with PTT switch
LBB9080/00	Handheld dynamic fist microphone (CB style) with 1.2m coiled cable
LBB9099/10	Uni-directional handheld dynamic mic with 1.2m coiled cord terminated with 5-pin DIN plug
SR785LN/O	Dynamic, Normally open PTT, Low Z, Gooseneck paging mic, Rugged Stainless Steel Construction. Ideal

**→ Bosch Commercial Electronics****Wireless Microphone Systems**

Code	Description
MW1-RX-F1	Bosch UHF diversity receiver 193 channel with LCD
MW1-HTX-F1	Bosch handheld microphone transmitter 193 channel
MW1-LTX-F1	Bosch bodypack transmitter 193 channel
MW1-LMC	Lavalier microphone (requires beltpack tx 010389)
MW1-RMB	Rack mount brackets & antenna adapter set to suit MW1-RX-F1 receiver

**Music Sources**

Code	Description
PLN-DVDT	CD / MP3 / DVD player and AM/FM tuner, background music source, separate audio outputs, video output
PLN-SDT	SD/USB player and AM/FM Tuner background music source, independent audio outputs for each source, in

Volume Controls and Source Selector Panels

Code	Description
LBC1402/10	Volume Control, 12 watts with Relay
LBC1402/20	Emergency Failsafe Volume Control, 12 Watts with relay
LBC1412/10	Volume Control, 36 watts with Relay
LBC1412/20	Emergency Failsafe Volume Control, 36 Watts with relay
LBC1420/10	Volume Control, 100 watts with Relay
LBC1420/20	Emergency Failsafe Volume Control, 100 Watts with relay
LBC1434/00	Source Selector, 5 channels plus off

Weekly Timer

Code	Description
PLN-6TMW	Weekly timer featuring 2 separate programs, 14 chimes, 6 contact outputs, automatic daylight savings

Digital Message Announcer

Code	Description
LBB1965/00	Digital message announcer, 12 message capacity at CD quality, 167s capacity at 24kHz sample rate, fu

Feedback Eliminator

Code	Description
LBB1968/00	Feedback Suppressor, 1RU, includes rack ears, 1RUx430x270mm, 3kg

MTS ION - Cobranet Audio Patching Solutions

Code	Description
ION0.2-O/P	ION0.2 Wall Mount 2 Channel CNET Output I/F
ION2.0-I/P	ION2.0 Wall Mount 2 Channel CNET Input I/F
ION4.4	ION4.4 4x Channel Mic/Line:Output Line, CNET I/F
ION8.8	ION8.8: 8x Channel Mic/Line:Output Line, CNET I/F

Plena VAS Combined PA and Emergency Sound

Code	Description
LBB1956/00	Plena VAS Call Station - Six Zone Paging Buttons & All Call button
LBB1957/00	Plena VAS Call Station Keypad - expands Call Station by 6x programmable buttons
LBB1990/00	Plena VAS System Controller featuring six zones with individual vol. control, built-in message manag
LBB1992/00	Plena VAS Router - expands Plena VAS by 6 Zones
LBB1995/00	Plena voice alarm fireman's panel
LBB1996/00	Plena voice alarm remote control
LBB1997/00	Plena voice alarm remote control ext
LBB1998/00	Plena voice alarm remote control kit
LBB1999/00	Plena voice alarm remote control extension kit
PLN-1EOL	Plena vas eol board - pack of 6
PLN-DMY60	Plena vas dummy load board - pack of 12

Ceiling Loudspeakers BCS-CS

Code	Description
BCS-CS4BW	4" Easyfit ceiling speaker with 100V line tx with taps at 5,2.5,0.6 & 0.3W. 94dB SPL 1W/1m, 140mm cut out
BCS-CS4EM	4" Easyfit ceiling speaker with 100V line tx with taps at 5,2.5,0.6 & 0.3W. 94dB SPL 1W/1m, 140mm cut out
BCS-CS5BW	5" Easyfit ceiling speaker with 100v line tx with taps at 5, 2.5, 1, 0.6, 0.33W. 90dB SPL 1W/1m, 170mm cut out
BCS-CS6E	6.5" Easyfit ceiling speaker with 100v line tx with taps at 10, 5, 2.5, 1.25W. 91dB SPL 1W/1m, 195mm cut out
BCS-CS8BW	8" Easyfit ceiling speaker with 100v line tx with taps at 15, 10, 5, 2.5, 1.25W. 93dB SPL 1W/1m, 238mm cut out
BCS-CS830E	8" Easyfit ceiling speaker with 100v line tx with taps at 30, 15, 7.5, 3.75W. 93dB SPL 1W/1m, 238mm cut out

Ceiling Loudspeaker Spring Mount - 6 Inch

Code	Description
LBC3080/01	Steel firedome for LBC 3090/31 & LBC 3090/01 loudspeakers, Colour: Flame red (RAL 3000)
LBC3081/02	Steel firedome to suit the LBC3086/41 ceiling speaker, (red flame colour RAL3000)
LBC3086/41	Spring mount voice alarm ceiling speaker, 6" dual cone, integral metal grille, 6 watts 100v line wit
LBC3090/01	Spring mount 6" dual cone ceiling speaker, integral plastic grille, 6 watts, 100v line with taps at
LBC3090/31	Spring mount 6" dual cone ceiling speaker with terminal block for cable connection, integral metal g
LBC3091/01	Surface mounting box for LBC 3090/01 ceiling speaker, Colour: Off white (RAL 9010)

Ceiling Loudspeaker Spring Mount - 8 Inch

Code	Description
LBC3082/00	Steel firedome for LBC 3099/41 ceiling speaker
LBC3099/41	Spring mount 8" dual cone ceiling speaker with metal grille, 24 watts, 100v line with taps at 24, 12

Ceiling Loudspeaker High Performance

Code	Description
C4.2	Recessed Ceiling Prosound Lsp 30W 4" (2PCS)
C8.2	Recessed Ceiling Prosound Lsp 30W 8" (2PCS)
C8.2HC	Recessed Ceiling Prosound Lsp 60W 8" high ceiling (2PCS)
C8.2LP	Recessed Ceiling Prosound Lsp 30W 8" Low Profile (2PCS)
C10.1	Recessed Ceiling Prosound Lsp 60W 10" Sub (2PCS)
C12.2	Recessed Ceiling Prosound Lsp 60W 12" Full range (1 PC)

Horn Speakers General Horn Range

Code	Description
BCS-HS10E	Round horn speaker, grey colour, 10w with taps at 10, 5, 2.5, 1.25 watts, comes with metal U mount
BCS-HS20E	Round horn speaker 245mm diam, grey, 20w with taps at 20, 10, 5, 2.5 watts, comes with metal U-mount
LBC3470/00	Round horn speaker, light grey ABS, 15w 100v line with taps at 15, 7.5 & 3.75 watts
LBC3491/12	Rectangular horn, 267x171mm opening, light grey ABS, 10 watts 100v line with taps at 10, 5 & 2.5 watt
LBC3493/12	Round horn, 400mm opening, light grey aluminium/ABS, 30 watts 100v line with taps at 30, 15 & 7.5 watt
LBC3483/00	Round horn speaker, 490mm diam. Aluminium. 50W
LBC3484/00	Round horn speaker, 490mm diam. Aluminium. 75W

Horn Speakers Marine Grade

Code	Description
LBC3428/00	Marine horn protected to IEC60529 - IP66 and IP67, 163mm opening, 15 watts 100v line taps

Horn Speakers Music Quality

Code	Description
LH1-UC30E	2 way CD horn, rectangular, light grey ABS, 30 watts 100v line with taps at 30, 15, 7.5 & 3.75 watts

→ Bosch Commercial Electronics

BOSCH

Invented for life

Horn Drivers - 9000 Series

Code	Description
LBN9000/00	15w horn driver, 100v line with taps at 15, 7.5, 3.75 W
LBN9001/00	30w horn driver, 100v line with taps at 30, 15, 7.5 W
LBN9003/00	50w horn driver, 100v line with taps at 50, 25, 12.5 W

Horn Flares - 9000 Series

Code	Description
LBC3403/16	Round Horn Flare without driver - 10" Suits 9000 series
LBC3404/16	Round Horn Flare without driver - 15" Suits 9000 series
LBC3405/16	Round Horn Flare without driver - 20" Suits 9000 series
LBC3406/16	Rectangular Horn Flare without driver - 15"x 8" Suits 9000 series Drivers

Intrinsically Safe Horns - Explosion & Flame Proof

Code	Description
LBC3437/00	Explosion flameproof horn, 15 watts, 100v line with taps at 15, 7.5, 5, 4, 2, & 0.8 watts, black col
LBC3438/00	Explosion flameproof horn, 25 watts, 100v line with taps at 25, 12.5, 6, 4, 2 and 1 watt, 100dB SPL

Cabinet Loudspeakers Panel Loudspeakers - ABS

Code	Description
LBC3011/41	Panel loudspeaker designed for flush or surface mounting, 6 watts 100v line, taps at 6, 3, 1.5 and 0
LBC3011/51	Panel loudspeaker designed for flush or surface mounting, 6 watts 100v line, taps at 6, 3, 1.5 and 0
LBC3012/01	Surface mounting box for speaker LBC 3011/41 or 51
LBC3013/01	Flush mounting box for speaker LBC 3011/41 or 51

Cabinet Loudspeaker - Metal Vandal resistant

Code	Description
LBC3018/00	Metal cabinet loudspeaker. Surface or recess mounted, 6 watts 100v line with taps at 6, 3, 1.5 and 0

Cabinet Loudspeakers - MDF

Code	Description
LB1-CW06-L	6 watt corner cabinet loudspeaker, MDF, 90dB
LB1-UW06-D	6 watt cabinet loudspeaker, MDF, 91dB SPL 1w/1m
LB1-UW06-L	6 watt cabinet loudspeaker, MDF, 91dB SPL 1w/1m
LB1-UW06V-D	6 watt cabinet loudspeaker with volume control, 91dB
LB1-UW06V-L	6 watt cabinet loudspeaker with volume control, 91dB

Cabinet Loudspeakers - Moulded ABS

Code	Description
LB2-UC15-D	2 way music cabinet 4" woofer & 0.5" HF. 15W 100v line (22.5W at 8 ohms) taps at 15, 7.5, 3.75 & 1.9
LB2-UC15-L	2 way music cabinet 4" woofer & 0.5" HF. 15W 100v line (22.5W at 8 ohms) taps at 15, 7.5, 3.75 & 1.9
LB2-UC30-D	2 way music cabinet 5" woofer & 0.5" HF. 30W 100v line (45W at 8 ohms) taps at 30, 15, 7.5 & 3.75 Wa
LB2-UC30-L	2 way music cabinet 5" woofer & 0.5" HF. 30W 100v line (45W at 8 ohms) taps at 30, 15, 7.5 & 3.75 Wa

Cabinet Loudspeakers - Metal Weatherproof

Code	Description
LB1-UM20E-D	20W Aluminium Cabinet Loudspeaker, IP65 Charcoal
LB1-UM20E-L	20W Aluminium Cabinet Loudspeaker, IP65 White
LB1-UM50E-D	50W Aluminium Cabinet Loudspeaker, IP65 Charcoal
LB1-UM50E-L	50W Aluminium Cabinet Loudspeaker, IP65 White

Cabinet Loudspeakers - Premium High Output

Code	Description
LB3-PC250	250W 100V line moulded plastic cabinet loudspeaker - 12" mid/low, 1" HF
LB3-PC350	350W 100V line moulded plastic cabinet loudspeaker - 15" mid/low, 1" HF

Column Loudspeakers External Metal Weatherproof

Code	Description
LA1-UM20E	Metal column loudspeaker IP65 rated, 100V line with taps at 20, 10, 5, 2.5W as well as a 35W, 8 ohm
LA1-UM40E	Metal column loudspeaker IP65 rated, 100V line with taps at 40, 20, 10, 5W as well as a 60W, 8 ohm s

XL3200 Line Array XLA "Xtended Line Array"

Code	Description
LBC1259/00	Loudspeaker floorstand for XLA3200 range
LBC3200/00	XLA line array column, 30 watts, 100v line, taps at 30, 15 & 7.5 watts, 93dB SPL 1w/1m, silver colour
LBC3201/00	XLA line array column, 60 watts with taps at 60, 30 and 15 watts, 92dB SPL 1w/1m, silver colour
LBC3210/00	XLA line array column, 60 watts with taps at 60, 30 and 15 watts, 92dB SPL 1w/1m, 9kg, silver colour
LM1-CB	XLA carry bag for two floor stands

VARI-DIRECTIONAL - Digital Steerable Line Array

Code	Description
LA3-VARI-B	VARI-DIRECTIONAL BASE UNIT
LA3-VARI-BH	VARI-DIRECTIONAL BASE UNIT WITH EXTENDED HIGH FREQUENCY
LA3-VARI-CM	VARI-DIRECTIONAL COBRANET MODULE
LA3-VARI-CS	VARI-DIRECTIONAL CONFIGURATION SET
LA3-VARI-E	VARI-DIRECTIONAL EXTENSION UNIT

Sound Projectors Pendant Speakers (Spheres)

Code	Description
LBC3095/15	10W pendent sphere, 100V line tx taps at 10, 5 & 2.5W, 89dB SPL 1W/1m, 130Hz - 20kHz, off white
LS1-UC20E-1	20W pendent sphere, modern state-of-the-art styling, IP65 rated, 100v line with taps

Sound Projectors

Code	Description
LBC3430/02	12 watt bi-directional metal housing sound projector, IP55 rated, ceiling or wall mounted. 100v line
LBC3432/02	20 watt uni-directional metal housing sound projector, IP66 rated, ceiling or wall mounted. 100v line
LP1-BC10E-1	10 watt bi-directional ABS sound projector, modern styling, IP65 rated, ceiling or wall mounted. 100 line
LP1-UC10E-1	10 watt uni-directional ABS sound projector, modern styling with an omni style bracket, IP65 rated
LP1-UC20E-1	20 watt uni-directional ABS sound projector, modern styling with an omni style bracket, IP65 rated

Hemi-Directional Loudspeaker

Code	Description
LM1-MSB	Hemi-directional suspension bracket for fixed mounting to eradicate swinging.
LS1-OC100E-1	Hemi-directional loudspeaker - 100V line with taps at 100, 50 & 25W. Maximum 600m floor coverage.

Conferencing and Discussion Systems - CCS 900

Code	Description
CCS-CML900	Chairman's microphone unit, long microphone
CCS-CMS900	Chairman's microphone unit, short microphone
CCS-CU900	Master control unit
CCS-CUD900	Master control unit - Digital Anti Feedback
CCS-CURD900	Master control unit - Digital Anti-Feedback & Rec.
CCS-DL900	Delegate's unit, long microphone
CCS-DS900	Delegate's unit, short microphone
CCS-SC6900	Portable case for 1x control unit, 6x delegate units
CCS-SC10900	Portable suitcase for 10 x discussion units
LBB3311/00	19" mounting brackets
LBB3316/00	System installation pack. (100 metres of CCS900 cable + 5 male + 5 female connectors)
LBB3316/05	Extension cable assembly, 5 metres
LBB3316/10	Extension cable assembly, 10 metres